

## Table of Contents

1.4	EROSION AND SEDIMENTATION CONTROL CRITERIA .....	3
1.4.1	...Introduction.....	3
1.4.2	...City of Austin Erosion and Sedimentation Control Policy .....	4
A.	Purpose and Application.....	4
B.	Policy.....	4
C.	Plans and Computations.....	5
D.	Ordinance Authority.....	5
E.	Innovative and Alternative Practices .....	6
1.4.3	...Definitions (in accordance with TPDES General Permit and COA technical manuals).....	6
1.4.4	...Plan Development and Implementation.....	13
A.	Erosion and Sedimentation Control Process Outline.....	13
B.	Construction Phase Controls .....	14
C.	Plan Review Procedures.....	27
D.	Procedures During Construction.....	28
E.	Failure to Complete a Project.....	35
F.	Maintenance Responsibilities After Construction.....	35
G.	Additional Recommendations and Requirements for Selected Projects.....	35
1.4.5	...Temporary Structural Practices .....	40
A.	Mulching .....	40
B.	Diversion, Interceptor and Perimeter Dikes.....	43
C.	Interceptor and Perimeter Swales.....	45
D.	Stone Outlet Structures.....	46
E.	Rock Berm.....	47
F.	Mulch Socks.....	48
G.	Silt Fence.....	52
H.	Triangular Sediment Filter Dikes.....	61
I.	Hay Bale Dikes.....	62
J.	Mulch Berm.....	63
K.	Sediment Basin.....	66
L.	Sediment Trap.....	76
M.	Sediment Trapping Devices for Excavation Pumpage.....	78
N.	Stabilized Construction Entrance.....	79
O.	Pipe Slope Drain.....	80
P.	Inlet Protection.....	81
1.4.6	...Permanent Structural Practices.....	82
A.	Diversion.....	82
B.	Standards for Grass-Lined Swales.....	84
C.	Level Spreader.....	85
D.	Stone Riprap.....	86
E.	Gabions.....	87
F.	Subsurface Drain.....	89
G.	Land Grading.....	92
H.	Grade Stabilization Structure (Paved Chute or Flume).....	93
1.4.7	...Vegetative Practices.....	95

A.	Temporary Vegetative Stabilization of Disturbed Areas .....	95
B.	Permanent Vegetative Stabilization of Disturbed Areas .....	98
C.	Stabilization of Disturbed Areas with Trees, Perennials, Grasses and Shrubs. ....	102
1.4.8	...Special Practices .....	104

## Index of Figures

Figure 1.4-A	Mulching Detail .....	43
Figure 1.4-B	Typical Mulch Sock Detail .....	52
Figure 1.4-C	Influent Particle Size Distribution .....	56
Figure 1.4-D	Silt Fence Installation .....	57
Figure 1.4-E	Silt Fence Typical Placement – One Slope .....	58
Figure 1.4-F	Silt Fence Typical Placement – Two Slopes .....	60
Figure 1.4-G	Silt Fence Placement for Perimeter Control.....	60
Figure 1.4-H	Silt Fence J - Hook Detail (N.T.S.) .....	61
Figure 1.4-I	Mulch Berm.....	65
Figure 1.4-J	Schematic of a Skimmer ( <i>from Pennsylvania Erosion and Sediment Pollution Control Manual, March 2000</i> ).....	67
Figure 1.4-K	Skimmer orifice diameter as a function of the basin volume and basin dewatering time. Rev. 6/06 6.64.3 .....	68
Figure 1.4-L	Example of a Sediment Basin with a Skimmer Outlet and Emergency Spillway ( <i>from Pennsylvania Erosion and Sediment Pollution Control Manual, March 2000</i> ).....	71

## Index of Tables

Table 1.4-A	Mulch Sock Slopes, Maximum Slope Lengths, and Sock Diameters .....	51
Table 1.4-B	Maximum spacing between silt fences on slopes.....	54
Table 1.4-C	Mulch Berm Slopes and Maximum Slope Lengths.....	65
Table 1.4-D	Skimmer Design Criteria .....	68
Table 1.4-E	Pipe Slope Drain Sizes .....	80
Table 1.4-F	Pipe Slope Drain Sizes .....	82
Table 1.4-G	Roughness Coefficient for Gabions .....	87
Table 1.4-H	Apron Length.....	88
Table 1.4-I	Grade Stabilization Structure Size Data .....	94
Table 1.4-J	Hydromulching for Temporary Vegetative Stabilization .....	96
Table 1.4-K	Properties of 70/30 Wood/Cellulose Blend Fiber Mulch .....	97
Table 1.4-L	Properties of Wood Fiber Mulch .....	97
Table 1.4-M	Hydromulching for Permanent Vegetative Stabilization.....	99
Table 1.4-N	Properties of Bonded Fiber Matrix.....	100
Table 1.4-O	Properties of Fiber Reinforced Matrix .....	100
Table 1.4-P	Watering Schedule .....	102
Table 1.4-Q	Weeding Schedule .....	102
Table 1.4-R	Irrigation Schedule .....	103
Table 1.4-S	Weeding Schedule .....	104
Table 1.4-T	Spray-on Adhesives.....	106

## **1.4 EROSION AND SEDIMENTATION CONTROL CRITERIA**

### **1.4.1 Introduction**

The purpose of this section is to provide a resource document and policy for the protection of land and water resources, so as to minimize the adverse effects of erosion and sedimentation per the City of Austin's Land Development Code. Additionally, the criteria have been fashioned to complement the language of the Texas Pollution Discharge Elimination System (TPDES) General Permit.

The conversion of land from its natural state or agricultural use to urban use accelerates the processes of erosion and sedimentation. These negatively impact the city's drinking water supply, aquatic life and the recreational resource provided by them.

Construction related sediment can be a significant pollutant of streams, lakes, ponds and reservoirs. Not only does sediment reduce the quality of water for boating, fishing, swimming and other water-oriented recreation, it also creates maintenance problems due to excessive wear on pumps and due to the reduced capacity of streams, lakes and other waterways. Another problem associated with sediment is the affinity of pesticides, phosphates and many other chemical pollutants for soil particles. These pollutants are carried to the waterway on the sediment and further reduce the quality of the water.

Mankind accelerates the erosion process by modifying the topography, soil conditions, vegetative cover and drainage patterns during construction to suit its needs. The clearing and grading of land to convert it from a natural state to cultivated row crops greatly increases the potential for erosion. The magnitude of this increase can be as much as 200 times. In addition, earth moving and construction to convert agricultural land to urban uses such as roads, houses, shopping centers, schools and airports increases the erosion potential another ten (10) times (Erosion and Sedimentation Control Guidelines for Developing Areas in Texas, U.S.D.A., S.C.S., Temple, Texas, 1976). After full urbanization takes place in a watershed, however, erosion usually decreases several fold from that experienced during the period of construction (Virginia Erosion and Sedimentation Control Handbook, Second Edition, 1980) and may decrease from that occurring before construction.

As additional development and urban growth takes place in Austin, the value of all land and water resources increases. The conservation of these resources is easier and less expensive than their restoration.

On most development projects, the major period for erosion potential exists between the time when the existing vegetation is removed to begin site work and the completion of construction and revegetation. There are numerous activities associated with construction and land development that accelerate the rate of erosion. Virtually all of these actions involve the removal of vegetation and/or the movement of the native geologic structure to provide a construction site. The adverse impact upon the site and the environment in general can be reduced if these actions are taken with some thought to the resultant erosion.

The control criteria included in this manual provide several methods to address the dual problems of erosion and sedimentation, but are in no way a complete outline of the possible actions to provide adequate reductions. We therefore encourage innovation and suggestions to improve or expand on these concepts. Any questions concerning the

criteria or the use of measures not included in the manual should be directed to the Watershed Protection and Development Review Department.

The Erosion and Sedimentation Control Criteria are established and reviewed by the Environmental Resource Management Division of the Watershed Protection and Development Review Department. Site plan review is conducted by the Land Use Review Division and construction inspection oversight by the Environmental Inspection Section of the Site and Subdivision Inspection Division.

## **1.4.2 City of Austin Erosion and Sedimentation Control Policy**

### ***A. Purpose and Application.***

The City of Austin Erosion and Sedimentation Control policy shall govern the planning, design, installation, maintenance and inspection of temporary and permanent erosion and sedimentation controls associated with development within the City of Austin and all areas subject to its extraterritorial jurisdiction. Finally, this policy is the official criteria manual required by the TPDES MS4 permit, and as such strives to comply with all federal and state mandates updating the permit. At this time, neither the NPDES nor the TPDES General Permits require Effluent Limit Guidelines (ELG). However, as of November, 2008, EPA has sent notice that it will impose ELG upon Construction General Permits. At such time, COA will update ECM 1.4 to comply with EPA mandates.

### ***B. Policy.***

It shall be the policy of the City of Austin that erosion and sedimentation controls are required for all construction and development, conducted with or without a permit, including without limitation commercial, multi-family, single-family, and duplex construction, the construction of all roads, utilities, parks, golf courses, water quality basins, detention basins, and all other activities utilizing clearing, trenching, grading or other construction techniques. It is the intent of City of Austin policy to closely parallel the requirements set forth in the Texas Pollution Discharge Elimination System (TPDES) Construction General Permit, the City of Austin's MS4 permit and any applicable updates to NPDES or TPDES.

The objectives of this policy are to:

- Minimize the erosion and transport of soil resulting from development activities.
- Prevent sedimentation in streams, creeks, lakes, waterways, storm drains, etc by ensuring no off-site transport of disturbed sediment for the 2 year 24 hour storm during construction and through establishment of permanent controls.
- Protect and improve the quality of surface water in the Austin environment and maintain and improve the quality and quantity of recharge to groundwater supplies, especially the Edwards aquifer.
- Minimize flooding hazards and silt removal cost associated with excessive sediment accumulation in storm drains and waterways.
- Preserve and protect existing vegetation to the greatest extent possible, particularly native plant and wildlife habitats.

- Reduce paperwork and redundancy by adopting submittal requirements of TPDES Stormwater Pollution Prevention Plans (SWPPP).

The following sections present the minimum requirements for the planning, design, construction, operation and maintenance of erosion and sedimentation control facilities and should be used as a resource document to help developers and engineers plan and implement their projects to provide protection from erosion or sedimentation. The adequacy of the SWPPP to meet the letter and intent of this section will be determined by the Watershed Protection and Development Review Department. Please note that projects that require a building permit, but not a site plan permit, are required to complete the TPDES Construction Site Notice (Small or large depending on size. See Appendix V, Figures 1-2, 1-3, 1-4, 1-5. Or click on TCEQ link at:

<http://www.tceq.state.tx.us/assets/public/permitting/waterquality/attachments/stormwater/tr150000.pdf>

Figure 1-1.1 (Appendix V) outlines the general sequence of events that take place in the planning, review, approval, construction and inspection of an Erosion and Sedimentation Control Plan. See Section 1.4.4(B)3 for the E&S control plan submittal requirements. The City of Austin and the Watershed Protection and Development Review Department shall not be responsible to anyone for the use or reliance on any portion of this manual and shall not incur any obligation or liability for damages, including consequential damages, arising out of or in connection with the use, interpretation, or reliance on any specification or guidelines contained herein.

### ***C. Plans and Computations.***

Plans and computations to support all erosion and sedimentation control designs shall be submitted to the Watershed Protection and Development Review Department for review. Plans and computations shall be in such form as to allow for timely and consistent review and to be made a part of the permanent record for future reference. Computations shall be required for BMPs that rely on detention, sedimentation, filtration, diversion and velocity control. The reviewer may deny an application if the applicant cannot support Erosion and Sedimentation control designs with appropriate calculations All engineering computations shall be certified by a Registered Professional Engineer specializing in Civil Engineering and beginning on October 4, 2010 all SWPPPs shall be signed by a Certified Professional in Erosion and Sedimentation Control {(CPESC)( <http://cpesc.org/>)} If the SWPPP itself contains engineering calculations, then the Registered Professional Engineer must also seal and sign the SWPPP. All drainage calculations shall be done in accordance with the guidelines in the Drainage Criteria Manual.

### ***D. Ordinance Authority.***

The information in the following sections is intended to define the technical design criteria needed to achieve the policy goals identified in the Land Development Code relating to erosion and sedimentation control. A brief summary of specific code sections relating to the requirements for erosion and sedimentation control is included below:

#### **Title 6-5-51: Discharges into Storm Sewers or Watercourses.**

- 25-1-441: Cease and desist order ("Red Tag").
- 25-1-288: Requirements for a pre-construction inspection; owner's demonstration of compliance; modifications to controls and plans.
- 25-7-61 and 25-7-65: Adequate temporary and permanent erosion and sedimentation control plans required for final plat, subdivision construction plan, or site plan approval; estimated cost of fiscal security; fiscal security insures no cost to the city.
- 25-8-181 to 25-8-184: Erosion and sedimentation control required for all construction; restoration required for a complete project; modifications to plans allowed.
- 25-8-321 to 25-8-323: Topsoil to be protected against erosion; existing vegetation to be left in place where possible; limitation of time between rough cutting and final surfacing of roadways.
- 25-8-341 and 25-8-342: Cuts and fills to be restored and stabilized.
- 25-8-343: Restoration and revegetation of spoil disposal sites required.
- 25-8-281 and 25-8-282: Special erosion controls required to protect critical environmental features.
- Work done under this policy is subject to all provisions of the Land Development Code. No work shall be done by the contractor until all required permits have been obtained. To find out exactly what permits are required, an inquiry should be made to the Watershed Protection and Development Review Department.

***E. Innovative and Alternative Practices .***

Innovative practices or alternatives to those presented in this section, are not considered or approved by staff on a case by case basis. Rather, twice each year, staff evaluates new technologies and suggestions and determines which practices to formally adopt into the manual. The ECM will then be formally updated by the rules adoption process to allow use of these products/technologies across all appropriate projects. Suggestions or requests for product evaluation should be submitted to the Manager of the Stormwater Treatment Section of Environmental Resources Management.

**1.4.3 Definitions (in accordance with TPDES General Permit and COA technical manuals)**

**Arid Areas** – Areas with an average annual rainfall of 0 to 10 inches.

**Baseflow** – The discharge in a channel that is relatively constant, occurring between storm runoff events. That flow which can be expected on a daily basis without storm flows.

**Best Management Practices (BMPs)** – Schedules of activities, prohibitions of practices, maintenance procedures, structural controls, local ordinances, and other management practices to prevent or reduce the discharge of pollutants. BMPs also include treatment requirements, operating procedures, and practices to control

construction site runoff, spills or leaks, waste disposal, or drainage from raw material storage areas.

**Bonded Fiber Matrix (BFM)** – Bonded Fiber Matrix shall consist of long thermally refined wood fibers produced from grinding clean, whole wood chips and cross-linked hydro-colloidal tackifiers.

**Certified Inspector** – A person who has received training and is licensed by CPESC or CISEC to inspect and maintain erosion and sediment control practices.

**Clearing** – Any activity that removes the vegetative surface cover. Mass clearing is defined as the practice of clearing the entire site of all vegetation (except protected trees) to prepare for final grading. This is opposed to Selective clearing, which only disturbs the soil and vegetation where a road or infrastructure will be placed.

**Commencement of Construction** – The initial disturbance of soils associated with clearing, grading, or excavation activities, as well as other construction-related activities (e.g., stockpiling of fill material, demolition)

**Common Plan of Development** – A construction activity that is completed in separate stages, separate phases, or in combination with other construction activities. A common plan of development (also known as a “common plan of development or sale”) is identified by the documentation for the construction project that identifies the scope of the project, and may include plats, blueprints, marketing plans, contracts, building permits, a public notice or hearing, zoning requests, or other similar documentation and activities. A common plan of development does not necessarily include all construction projects within the jurisdiction of a public entity (e.g., a city or university). Construction of roads or buildings in different parts of the jurisdiction would be considered separate “common plans,” with only the interconnected parts of a project being considered part of a “common plan” (e.g., a building and its associated parking lot and driveways, airport runway and associated taxiways, a building complex, etc.). Where discrete construction projects occur within a larger common plan of development or sale but are located  $\frac{1}{4}$  mile or more apart, and the area between the projects is not being disturbed, each individual project can be treated as a separate plan of development or sale, provided that any interconnecting road, pipeline or utility project that is part of the same “common plan” is not included in the area to be disturbed.

**Discharge** – For the purposes of this permit, the drainage, release, or disposal of pollutants in storm water and certain non-storm water from areas where soil disturbing activities (e.g., clearing, grading, excavation, stockpiling of fill material, and demolition), construction materials or equipment storage or maintenance (e.g., fill piles, borrow area, concrete truck washout, fueling), or other industrial storm water directly related to the construction process (e.g., concrete or asphalt batch plants) are located.

**Drainage Way** – Any channel that conveys surface runoff throughout the site.

**Edwards Aquifer** – As defined under Texas Administrative Code § 213.3 of this title (relating to the Edwards Aquifer), that portion of an arcuate belt of porous, water-bearing, predominantly carbonate rocks known as the Edwards and Associated Limestones in the Balcones Fault Zone trending from west to east to northeast in Kinney, Uvalde, Medina, Bexar, Comal, Hays, Travis, and Williamson Counties; and composed of the Salmon Peak Limestone, McKnight Formation, West Nueces Formation, Devil’s River Limestone, Person Formation, Kainer Formation, Edwards Formation, and Georgetown Formation. The permeable aquifer units generally overlie the less-permeable Glen Rose Formation to the south, overlie the less permeable

Comanche Peak and Walnut Formations north of the Colorado River, and underlie the less permeable Del Rio Clay regionally.

**Edwards Aquifer Recharge Zone** – Generally, that area where the stratigraphic units constituting the Edwards Aquifer crop out, including the outcrops of other geologic formations in proximity to the Edwards Aquifer, where caves, sinkholes, faults, fractures, or other permeable features would create a potential for recharge of surface waters into the Edwards Aquifer. The recharge zone is identified as that area designated as such on official maps located in the offices of the Texas Commission on Environmental Quality and the Construction General Permit TPDES General Permit TXR150000 The Edwards Aquifer Map Viewer, located at:

[http://www.tceq.state.tx.us/compliance/field\\_ops/eapp/mapdisclaimer.html](http://www.tceq.state.tx.us/compliance/field_ops/eapp/mapdisclaimer.html),

can be used to determine where the recharge zone is located.

**Edwards Aquifer Contributing Zone** - The area or watershed where runoff from precipitation flows downgradient to the recharge zone of the Edwards Aquifer. The contributing zone is located upstream (upgradient) and generally north and northwest of the recharge zone for the following counties: all areas within Kinney County, except the area within the watershed draining to Segment 2304 of the Rio Grande Basin; all areas within Uvalde, Medina, Bexar, and Comal Counties; all areas within Hays and Travis Counties, except the area within the watersheds draining to the Colorado River above a point 1.3 miles upstream from Tom Miller Dam, Lake Austin at the confluence of Barrow Brook Cove, Segment 1403 of the Colorado River Basin; and all areas within Williamson County, except the area within the watersheds

draining to the Lampasas River above the dam at Stillhouse Hollow reservoir, Segment 1216 of the Brazos River Basin. The contributing zone is illustrated on the Edwards Aquifer map viewer at:

[http://www.tceq.state.tx.us/compliance/field\\_ops/eapp/mapdisclaimer.html](http://www.tceq.state.tx.us/compliance/field_ops/eapp/mapdisclaimer.html).

**Erosion Control** –A measure that prevents erosion.

**Erosion and Sediment** – A set of plans prepared by or under the direction of a certified professional

**Control Plan** – indicating the specific measures and sequencing to be used to control sediment and erosion on a development site during and after construction.

**Facility or Activity** – For the purpose of this permit, a construction site or construction support activity that is regulated under this general permit, including all contiguous land and fixtures (e.g., ponds and materials stockpiles), structures, or appurtenances used at a construction site or industrial site described by this general permit.

**Final Stabilization** - A construction site status where any of the following conditions are met:

(a) All soil disturbing activities at the site have been completed and a uniform (i.e., evenly distributed, without large bare areas) perennial vegetative cover with a density of at least 70% of the native background vegetative cover for the area has been established on all unpaved areas and areas not covered by permanent structures, or equivalent permanent stabilization measures (such as the use of riprap, gabions, or geotextiles) have been employed.

(b) For individual lots in a residential construction site by either:

(1) the homebuilder completing final stabilization as specified in condition (a) above; or  
(2) the homebuilder establishing temporary stabilization for an individual lot prior to the time of transfer of the ownership of the home to the buyer and after informing the homeowner of the need for, and benefits of, final stabilization. If temporary stabilization is not feasible, then the homebuilder may fulfill this requirement by retaining perimeter controls or other best management practices, and informing the homeowner of the need for removal of temporary controls and the establishment of final stabilization.

(c) For construction activities on land used for agricultural purposes (e.g. pipelines across crop or range land), final stabilization may be accomplished by returning the disturbed land to its preconstruction agricultural use. Areas disturbed that were not previously used for agricultural activities, such as buffer strips immediately adjacent to surface water and areas that are not being returned to their preconstruction agricultural use must meet the final stabilization conditions of condition (a) above.

(d) In arid, semi-arid, and drought-stricken areas only, all soil disturbing activities at the site have been completed and both of the following criteria have been met:

(1) Temporary erosion control measures (e.g., degradable rolled erosion control product) are selected, designed, and installed along with an appropriate seed base to provide erosion control for at least three years without active maintenance by the operator, and

(2) The temporary erosion control measures are selected, designed, and installed to achieve 70 percent vegetative coverage within three years.

**Fiber Reinforced Matrix (FRM).** Fiber Reinforced Matrix shall consist of long thermally refined wood fibers produced from grinding clean, whole wood chips, crimped interlocking fibers, cross-linked hydro-colloidal tackifiers and performance enhancing additives.

**Fugitive sediment** - Sediment resulting from earth disturbing activities that is mobilized by wind or water and transported from the construction site to any point outside the limits of construction.

**Grading** - Excavation or fill of material, including the resulting conditions thereof.

**Hyperchlorination of Waterlines** – Treatment of potable water lines or tanks with chlorine for disinfection purposes, typically following repair or partial replacement of the waterline or tank, and subsequently flushing the contents.

**Indian Country Land** – (from 40 CFR 122.2) (1) all land within the limits of any Indian reservation under the jurisdiction of the United States government, notwithstanding the issuance of any patent, and, including rights-of-way running through the reservation; (2) all dependent Indian communities with the borders of the United States whether within the originally or subsequently acquired territory thereof, and whether within or without the limits of a state; and (3) all Indian allotments, the Indian titles to which have not been extinguished, including rights-of-way running through the same.

**Indian Tribe** – (from 40 CFR 122.2) any Indian Tribe, band, group, or community recognized by the Secretary of the Interior and exercising governmental authority over a Federal Indian Reservation.

**Large Construction Activity** – Construction activities including clearing, grading, and excavating that result in land disturbance of equal to or greater than five (5) acres of land. Large construction activity also includes the disturbance of less than five (5) acres of total land area that is part of a larger common plan of development or sale if the larger

common plan will ultimately disturb equal to or greater than five (5) acres of land. Large construction activity does not include routine maintenance that is performed to maintain the original line and grade, hydraulic capacity, or original purpose of the site (e.g., the routine grading of existing dirt roads, asphalt overlays of existing roads, the routine clearing of existing right-of-ways, and similar maintenance activities.)

**Municipal Separate Storm Sewer System (MS4)** – A separate storm sewer system owned or operated by the United States, a state, city, town, county, district, association, or other public body (created by or pursuant to state law) having jurisdiction over the disposal of sewage, industrial wastes, storm water, or other wastes, including special districts under state law such as a sewer district, flood control or drainage district, or similar entity, or an Indian tribe or an authorized Indian tribal organization, that discharges to surface water in the state.

**Notice of Change (NOC)** – Written notification to the executive director from a discharger authorized under this permit, providing changes to information that was previously provided to the agency in a notice of intent form.

**Notice of Intent (NOI)** – A written submission to the executive director from an applicant requesting coverage under this general permit.

**Notice of Termination (NOT)** – A written submission to the executive director from a discharger authorized under a general permit requesting termination of coverage.

**Operator** – The person or persons associated with a large or small construction activity that is either a primary or secondary operator as defined below:

**Primary Operator** – the person or persons associated with a large or small construction activity that meets either of the following two criteria:

(a) the person or persons have operational control over construction plans and specifications, including the ability to make modifications to those plans and specifications; or

(b) the person or persons have day-to-day operational control of those activities at a construction site that are necessary to ensure compliance with a storm water pollution prevention plan (SWP3) for the site or other permit conditions (e.g., they are authorized to direct workers at a site to carry out activities required by the SWP3 or comply with other permit conditions).

**Secondary Operator** – The person whose operational control is limited to the employment of other operators or to the ability to approve or disapprove changes to plans and specifications. A secondary operator is also defined as a primary operator and must comply with the permit requirements for primary operators if there are no other operators at the construction site.

**Outfall** - For the purpose of this permit, a point source at the point where storm water runoff associated with construction activity discharges to surface water in the state and does not include open conveyances connecting two municipal separate storm sewers, or pipes, tunnels, or other conveyances that connect segments of the same stream or other water of the U.S. and are used to convey waters of the U.S.

**Perimeter Control** –A barrier that prevents sediment from leaving a site by detaining sediment-laden runoff or diverting it to a sediment trap or basin.

**Permanent Stabilization** – The use of practices that prevent exposed soil from eroding upon achieving final grade. Permanent stabilization includes a broad range of items such

as vegetation, structures which cover the soil to protect, paving, and post development stormwater controls that shall be implemented within 7 calendar days of achieving final grade.

**Permittee** – An operator authorized under this general permit. The authorization may be gained through submission of a notice of intent, by waiver, or by meeting the requirements for automatic coverage to discharge storm water runoff and certain non-storm water discharges.

**Phasing** – Clearing a parcel of land in distinct phases, with the stabilization of each phase completed before the clearing of the next.

**Point Source** – (from 40 CFR §122.2) Any discernible, confined, and discrete conveyance, including but not limited to, any pipe, ditch, channel, tunnel, conduit, well, discrete fissure, container, rolling stock concentrated animal feeding operation, landfill leachate collection system, vessel or other floating craft from which pollutants are, or may be, discharged. This term does not include return flows from irrigated agriculture or agricultural storm water runoff.

**Pollutant** – Dredged spoil, solid waste, incinerator residue, sewage, garbage, sewage sludge, filter backwash, munitions, chemical wastes, biological materials, radioactive materials, heat, wrecked or discarded equipment, rock, sand, cellar dirt, and industrial, municipal, and agricultural waste discharged into any surface water in the state. The term "pollutant" does not include tail water or runoff water from irrigation or rainwater runoff from cultivated or uncultivated rangeland, pastureland, and farmland. For the purpose of this permit, the term "pollutant" includes sediment.

**Pollution** – (from Texas Water Code §26.001(14)) The alteration of the physical, thermal, chemical, or biological quality of, or the contamination of, any surface water in the state that renders the water harmful, detrimental, or injurious to humans, animal life, vegetation, or property or to public health, safety, or welfare, or impairs the usefulness or the public enjoyment of the water for any lawful or reasonable purpose.

**Rainfall Erosivity Factor (R factor)** – the total annual erosive potential that is due to climatic effects, and is part of the Revised Universal Soil Loss Equation (RUSLE).

**Sediment Control** – Measures that prevent eroded sediment from leaving the site.

**Semi-arid Areas** – areas with an average annual rainfall of 10 to 20 inches

**Separate Storm Sewer System** – A conveyance or system of conveyances (including roads with drainage systems, streets, catch basins, curbs, gutters, ditches, man-made channels, or storm drains), designed or used for collecting or conveying storm water; that is not a combined sewer, and that is not part of a publicly owned treatment works (POTW).

**Site Development** – The construction or reconstruction of a building or road; the placement of a structure on land; the excavation, mining, dredging, grading or filling of land; the removal of vegetation from land; or the deposit of refuse or waste on land.

**Small Construction Activity** – Construction activities including clearing, grading, and excavating that result in land disturbance of equal to or greater than one (1) acre and less than five (5) acres of land. Small construction activity also includes the disturbance of less than one (1) acre of total land area that is part of a larger common plan of development or sale if the larger common plan will ultimately disturb equal to or greater than one (1) and less than five (5) acres of land. Small construction activity does not include routine maintenance that is performed to maintain the original line and grade,

hydraulic capacity, or original purpose of the site (e.g., the routine grading of existing dirt roads, asphalt overlays of existing roads, the routine clearing of existing right-of-ways, and similar maintenance activities.)

**Start of Construction** –The first land-disturbing activity associated with a development, including land preparation such as clearing, grading, and filling and demolition; installation of streets and walkways; excavation for basements, footings, piers, or foundations; erection of temporary forms; and installation of accessory buildings such as garages.

**Storm Water (or Storm Water Runoff)** – Rainfall runoff, snow melt runoff, and surface runoff and drainage.

**Storm Water Associated with Construction Activity** – Storm water runoff from a construction activity where soil disturbing activities (including clearing, grading, excavating) result in the disturbance of one (1) or more acres of total land area, or are part of a larger common plan of development or sale that will result in disturbance of one (1) or more acres of total land area.

**Structural Control (or Practice)** – A pollution prevention practice that requires the construction of a device, or the use of a device, to capture or prevent pollution in storm water runoff. Structural controls and practices may include but are not limited to: silt fences, earthen dikes, drainage swales, sediment traps, check dams, subsurface drains, storm drain inlet protection, rock outlet protection, reinforced soil retaining systems, gabions, and temporary or permanent sediment basins.

**Surface Water in the State** – Lakes, bays, ponds, impounding reservoirs, springs, rivers, streams, creeks, estuaries, wetlands, marshes, inlets, canals, the Gulf of Mexico inside the territorial limits of the state (from the mean high water mark (MHW) out 10.36 miles into the Gulf), and all other bodies of surface water, natural or artificial, inland or coastal, fresh or salt, navigable or non-navigable, and including the beds and banks of all water-courses and bodies of surface water, that are wholly or partially inside or bordering the state or subject to the jurisdiction of the state; except that waters in treatment systems which are authorized by state or federal law, regulation, or permit, and which are created for the purpose of waste treatment are not considered to be water in the state.

**Temporary Stabilization** – A condition where exposed soils or disturbed areas are provided a protective cover or other structural control to prevent the mobilization and migration of pollutants. Use of bark mulch, Fiber Reinforced Matrix (FRM), Bonded Fiber Matrix (BFM), soil retention blanket, Turf Reinforcement Mat (TRM), sod, rock rip rap, or other cover that prevents the detachment of soil particles until final stabilization is achieved.

**Waters of the United States** – (from 40 CFR, Part122, Section 2) Waters of the United States or waters of the U.S. means:

(a) all waters which are currently used, were used in the past, or may be susceptible to use in interstate or foreign commerce, including all waters which are subject to the ebb and flow of the tide;

(b) all interstate waters, including interstate wetlands;

(c) all other waters such as intrastate lakes, rivers, streams (including intermittent streams), mudflats, sandflats, wetlands, sloughs, prairie potholes, wet meadows, playa

lakes, or natural ponds that the use, degradation, or destruction of which would affect or could affect interstate or foreign commerce including any such waters:

(1) which are or could be used by interstate or foreign travelers for recreational or other purposes;

(2) from which fish or shellfish are or could be taken and sold in interstate or foreign commerce; or

(3) which are used or could be used for industrial purposes by industries in interstate commerce;

(d) all impoundments of waters otherwise defined as waters of the United States under this definition;

(e) tributaries of waters identified in paragraphs (a) through (d) of this definition;

(f) the territorial sea; and

(g) wetlands adjacent to waters (other than waters that are themselves wetlands) identified in paragraphs (a) through (f) of this definition. Waste treatment systems, including treatment ponds or lagoons designed to meet the requirements of CWA (other than cooling ponds as defined in 40 CFR '423.11(m) which also meet the criteria of this definition) are not waters of the United States. This exclusion applies only to manmade bodies of water which neither were originally created in waters of the United States (such as disposal area in wetlands) nor resulted from the impoundment of waters of the United States. Waters of the United States do not include prior converted cropland. Notwithstanding the determination of an area's status as prior converted cropland by any other federal agency, for the purposes of the Clean Water Act, the final authority regarding Clean Water Act jurisdiction remains with EPA.

**Watercourse** – Any body of water, including, but not limited to lakes, ponds, rivers, streams, and bodies of water delineated by City of Austin, USGS, USACE or TCEQ.

**Waterway** – A channel that directs surface runoff to a watercourse or to the public storm drain.

#### **1.4.4 Plan Development and Implementation**

##### ***A. Erosion and Sedimentation Control Process Outline.***

Implementation of an effective erosion and sedimentation control plan requires a project management approach where responsibility is assigned during each phase to assure proper design, installation, maintenance, inspection, and when necessary, repair or replacement of controls during the construction. The project owner, engineer and contractor are all integrally involved in this process from start to finish. In addition, an understanding by the responsible individuals of the complete process required to design and implement erosion and sedimentation controls will assist them in preparing appropriate plans, speed the review and approval process, result in fewer on-site changes or problems, and provide the appropriate degree of protection for the environment.

## **B. Construction Phase Controls**

### **1. General Concepts.**

The goal of erosion and sedimentation control is to limit as much as possible the detachment and transport of sediment from construction sites and the finished projects they eventually become.

Sediment is transported off-site through one of four means:

- Stormwater runoff,
- Water discharges (e.g. pumping of water out of trenches, open channels (creeks, rivers, ditches) or foundation and basement excavations),
- Vehicles, and
- Wind.

Stormwater runoff and water discharges are the primary means by which sediment is transported from construction sites. Sediment becomes suspended in runoff as it flows over or out of disturbed areas seeking the lowest path of least resistance. It is very important to realize that in order to control this suspended sediment, the means by which it is transported, water, must first be successfully controlled. The principal tasks are to keep the sediment from entering the runoff or, once in it, to separate and trap the suspended sediment before it can leave the site. The techniques to accomplish this consist of two basic types: site management practices and structural controls.

**Site management practices** – focus on the prevention of erosion and include methods such as minimizing the area of the site that is disturbed at any one time during construction, preserving the existing natural vegetation to the greatest extent feasible, covering exposed soils with temporary stabilization soon after disturbance and restoring vegetation as rapidly as possible in disturbed areas. A related method would be to revegetate between phases of a project, when there will be a delay between these phases. Additional site management techniques include keeping the velocity of stormwater below the erosive level, promoting sheet flow rather than concentrated flow, and protecting and maintaining stable slopes.

**Structural controls** – utilize engineered devices (such as channels, berms, silt fences, ponds, etc.) to keep sediment on-site. This is accomplished in a two-stage process consisting of drainage control followed by sediment removal.

**Drainage Control** – The control of on-site drainage is essential to the process, as this must be accomplished first in order to successfully separate and trap suspended sediment. Drainage control is accomplished by strategically placing structural controls at locations where they will intercept stormwater runoff as it flows towards the lower portions of a site. These control devices must be substantial enough to withstand the anticipated runoff velocity and either must direct the flow to another control device or must be shaped to temporarily pool the runoff behind the structure. At this point in the process, trapping of sediment can occur. If the

drainage control stage is unsuccessful or only partially successful, it will correspondingly limit the amount of sediment that will be trapped. Reviewers shall require calculations to demonstrate that drainage controls have the capacity to withstand the velocity of the 10 year 24 hour storm and all detention sedimentation controls shall be shown to have capture volume for the 2 year 24 hour storm as well as the volume of sediment generated from a two year 24 hour storm. Drainage controls shall have a drawdown time of 72 hours.

**Sediment Control** – Sediment trapping, i.e. the separation of the sediment from the runoff, occurs primarily by sedimentation when suspended materials settle out as runoff velocity is decreased, and the sediment is trapped and left behind to be removed later, while the runoff is released to drain off-site.

The other methods by which sediment leaves a site, vehicles and wind, can be controlled in a manner similar to runoff. The first step is to control the mechanism that moves the sediment and the second step is to capture the sediment. For vehicles this entails directing them to a limited number of stabilized exits where most of the attached soil or mud can fall or be washed off. Wind blown dust, although generally not a major problem, can be controlled with barriers that slow velocity and prevent transport. In addition, excessive dust can be controlled with regular wetting of the dust source. Special additives to the water used for dust control (i.e. dust palliatives) will assist in preventing the resuspension of dust when the moisture has evaporated. Article V, Chapter 4-3 of the City Code of 1981, however, does not allow the use of oil, diesel fuel or other pollutants which may wash into streams and watercourses for the control of dust.

The previous paragraphs describe the basic process that occurs in implementing successful structural erosion and sedimentation controls. Variations of this process can be employed, depending on the type, number, and location of structural control devices used. However, the basic concepts and engineering functions involved in successful erosion and sedimentation control applications remain the same regardless of which specific structural devices or techniques are employed. Whether or not a plan is judged to be able to adequately meet the letter and intent of the policy in 1.4.2 (B) will be determined by the Watershed Protection and Development Review Staff. Because each site is unique, this volume cannot prescribe an upfront pre-approved recipe that will ensure site plan approval. However, following the submittal requirements in section 3 will demonstrate to the reviewer that a thoughtful and rigorous analysis of the potential pollutants, runoff pathways, and methods for control have been considered.

In the following sections, design of temporary and permanent controls for sites are more fully examined.

## **2. Design Guidelines**

There are several methods available to reduce erosion and sedimentation problems at construction sites. Site management methods are one of the most economical ways to accomplish this control. This section introduces several new or underutilized methods that will be required as part of the

Plan Submittals. Phasing, limiting the extent of existing vegetation that is disturbed, planning the necessary locations of the disturbance, restricting construction traffic to those locations, and revegetating or otherwise stabilizing any disturbed area are examples of this type of planning, hereafter referred to as Prevention.

More common methods, however, use structural controls to take advantage of the reduced ability of water to carry sediment when its velocity is reduced. Temporary structural control devices can be grouped into one or more functional categories, defined by its particular application on a site. Recognition of the function of each control at the point where it is to be used is critical in choosing the most effective measure for each location. Three functional categories have been identified and are described below:

- **Diversion** – A control device used for diversion is strategically placed on a site to intercept runoff and divert it to another location. A diversion may be installed to keep clean water from crossing and eroding a disturbed area or to move runoff with silt to a location where it can be treated more effectively. (See COA Standard Detail 621 and 622, also included in Appendix V.) All sites that receive off-site runoff must install flow diversion devices designed to handle the concentrated flow and divert it around the disturbed area in a non-erosive manner to the receiving drainage system downstream of the site. Diversion capacity shall be the runoff volume of the 10 year, 24 hour storm. All diversions shall be designed to withstand erosion from the velocity of the 10 year 24 hour storm.
- **Flow Spreading/Velocity Reduction** – This category of control applies to smaller flow amounts which may be diverted onto undisturbed ground while at the same time allowing a small amount of flow to pass over and through the device. The control device can also function as a grade control to reduce the length and steepness of a slope to prevent rills and gullies. These controls are normally situated at a right angle to the flow path and are spaced to ensure not erosive velocities. This form of control attempts to restore a sheet flow condition such that the velocity and depth of flow are so low that sediment can not be effectively carried by the runoff. (See Figure 1.6.7 B.1 level spreader or rock berm.)
- **Detention/Sedimentation** – Runoff is ponded behind a structure allowing the sediment to drop out of suspension and be trapped in the detention pool because of the reduction in runoff velocity.

Previously, silt fences were classified as detention/filtration devices. Recent research by the University of Texas and Texas Department of Transportation demonstrated that silt fences function primarily as detention/sedimentation due to clogging of the pores. They were found often to be undersized and improperly installed as detention/sedimentation devices. Therefore, silt fence criteria in section 1.4 have been updated to reflect the actual function of silt fences under field conditions.

Detention/sedimentation structures must be designed to withstand the force and velocity from a 10-year frequency storm without failing. Larger

storms shall be bypassed via stabilized conveyances.. Those devices that employ sedimentation must provide the storage volume for the runoff from a 2-year, 24 hour storm under compacted site conditions. The sedimentation basins must be designed such that drawdown time is 72 hours via surface skimmers. The design must include considerations for overflows to ensure that the device and its detention pool remain intact. Detention/sedimentation structures shall not be sited in natural drainage channels, draws or ravines that are directly connected to off-site drainage features like creeks, rivers, ponds or recharge features. In particular, this means that silt fences shall not be used to control concentrated or channelized flow and sedimentation basins shall not be constructed in natural draws because failures of the earthen retaining system are often catastrophic to the downstream receiving waters.

The procedure for developing an effective erosion and sedimentation control plan (henceforth adopting the NPDES nomenclature of Stormwater Pollution Prevention Plan (SWPPP) for a construction project involves several required steps, as indicated below. During plan review, the City of Austin Plan reviewer shall have final authority regarding the proper implementation of the SWPPP. The submittals must demonstrate to the satisfaction of the reviewer that all potential sources of sediment and other construction related pollution have been identified and minimized. The plan shall not move forward until the reviewer has been satisfied that the letter and intent of this section have been satisfied.

### **3. Submittal Requirements**

Submittals to satisfy the requirements for Erosion & Sedimentation control plans consist of two parts:

- Completed Stormwater Pollution Prevention Plan template, modified to meet City of Austin requirements (see Appendix P-7).
- Site Plan sheets that include the graphics necessary to illustrate, review and construct the systems outlined in the SWPPP (specific submittal requirements enumerated and explained below, but at least one sheet showing existing conditions, one sheet showing site prep and grading operation, one sheet showing BMP layout, sequence of construction/phasing, one sheet showing final grades and permanent stabilization measures, one sheet with details and notes).

Beginning on October 4, 2010, the SWPPP must be signed and certified by a Certified Professional in Erosion and Sedimentation Control (CPESC). If SWPPP includes engineering calculations, then SWPPP must be sealed and signed by Registered Professional Engineer. Until October 4, 2010, the SWPPP may be submitted by either a CPESC or a Registered PE.

#### **Section 1 – Existing Conditions Site Evaluation, Assessment and Planning**

- Project Site Information (e.g. name, location)
- Contact Information/Responsible Parties (Owner, SWPPP designer, Construction Phase SWPPP contact)
- Representative photograph of site that shows the designer on-site.

- Description of Soils – Use NRCS Soil Survey, USGS or Bureau of Economic Geology Geologic maps. Geotechnical reports are acceptable to define subsurface soil properties.
- Delineation of existing topography and drainage patterns, including overland and concentrated flow; contributing drainage area for flow paths that drain at least 1 acre, presence or absence of baseflow, USGS stream type (ephemeral, intermittent or perennial)
- Slope steepness
- List the receiving water to which the site drains; if receiving water is impaired or subject to Total Maximum Daily Loads, list pollutants causing impairment and requirements in TMDL applicable to construction sites. State how SWPPP prevents discharge of these pollutants
- Description and location of Critical Environmental Features
- Photos and description of predominant vegetation

## **Section 2 – Construction Activities and Site Management Practices**

For examples, see:

[http://www.epa.gov/npdes/pubs/exampleswppp\\_residential.pdf](http://www.epa.gov/npdes/pubs/exampleswppp_residential.pdf)

- Nature of Construction Activity (e.g. residential, commercial, utility, etc.)
- Phasing and construction sequence plan– maps and schedules of disturbances, phasing, temporary and permanent stabilization. Phasing is a preventive measure defined as: One portion of the site is disturbed at any one time to construct the infrastructure necessary to complete that phase. Subsequent phases are not started until earlier phases are substantially complete and exposed soils are stabilized. In the case of subdivision construction, it is defined that the activities associated with ROW construction (including utilities) are distinct phases from the activities associated with mass clearing and grading for subdivisions, which are also distinct from the activities associated with individual lot construction. If the permit allows for all three activities, then the SWPPP must address the sequence, timing, appropriate BMPs, installation and maintenance for all three phases. In addition, ROW construction must be accepted prior to beginning the phase of clearing and grading or individual lot construction. If the application for subdivision development anticipates clearing and grading of individual lots, then the SWPPP must show the interior and perimeter controls that will be in place and maintained until final stabilization of individual lots. ROW and utility construction will not be accepted by the City of Austin if any mass grading on lots has occurred without an approved SWPPP that anticipates construction through permanent stabilization of individual lots. Stormwater ponds are accepted separate from other utilities and ROW.
- For site plan review purposes, the construction sequence must show the duration of each activity, as opposed to specific start and end

dates. Prior to the start of construction, though, the SWPPP must be updated with actual dates of start/finish for each activity outlined in the sequence. The SWPPP must be kept updated to reflect any changes, or the inspector may red tag the site. Environmental Inspection will make the determination regarding the level of submittal needed for SWPPP updates. The determination will follow these general guidelines: 1) if the changes do not require a site plan revision or correction (certain changes like changes to LOC require revisions) and the EV Inspector, PE and CPESC all agree on a revision to planned E&S controls, then the SWPPP update log can be used to document the updates. Any graphics that are necessary for documentation shall be physically added to the SWPPP file. The construction sequence shall include at a minimum, the following:

- a. Length of time to install construction phase E&S controls
  - b. Length of time for each identified phase of construction from initial groundbreaking to final grade and any intermediate steps that would require modification of E&S controls (temporary and permanent storm water ponds, clearing and grubbing, rough grade, final grade, utilities, roads, etc)
  - c. Identification of areas within the LOC that will require temporary stabilization and the times of installation, modification, removal. Sequencing of grading and cut and fill activities will be required to show how disturbed and stockpiled sediment is accounted for each time it is transported from initial disturbance to permanent stabilization. For subdivisions, the sequence must show when construction of utilities and ROW construction ends, when grading of lots begins and ends, and when the individual lot construction phase begins.
  - d. Identify schedule for permanent stabilization
  - e. Identify schedule for converting temporary controls to permanent functions (e.g. basins)
  - f. Identify schedule for removal of E&S controls
- Maintenance schedule for Construction Phase BMPs
  - Calculations of cut/fill volumes per phase; include description of how spoils will be handled during construction (e.g. kept on site, hauled off; if on-site how will spoils be protected from erosion?)
  - Identify all potential sources of pollution during construction (not just sediment); describe pollution control procedures and devices.

### **Section 3 – Grading & Erosion/ Sediment Control BMPs**

Plan sheets that show:

- a. Direction of flow during grading operations
- b. Location, description and calculations for off-site flow diversion structures
- c. Areas that will not be disturbed; natural features to be preserved

- d. Delineation of and contributing drainage area to each proposed BMP (e.g. silt fence, sediment basin, etc)
- e. Location and type of E&S BMPs for each phase of disturbance
- f. Calculations for BMPs as required
- g. Location and description of temporary stabilization measures
- h. Location of on-site spoils; description of handling and disposal of borrow materials; On-site permanent spoils disposal areas, including size, depth of fill and revegetation procedures. (Off-site disposal requires a separate site development permit. A note shall be made on the plan to specify that "the contractor shall notify the city's inspector about the location and permit number of the disposal site 48 hours prior to the removal.")
- i. Location of vehicle entrance, description of stabilization measures and procedures for removing accumulated sediment to prevent off-site transport

#### **Section 4: Permanent Stabilization**

It is required that submittals for permanent stabilization contain the same level of detail as that stated above for temporary controls. It is given that some of the language is only applicable to temporary controls, but when it is appropriate for the word "permanent" to be substituted for the word "temporary" in sections 1-3 above, it is the reviewer's prerogative to require such submittals without them being individually itemized again in section 4.

Additional requirements for permanent stabilization submittals include, but are not limited to:

- a. Location and type of permanent stabilization (e.g. vegetation, slope stabilization, sodding, seed/soil retention blanket, Fiber Reinforced Matrix, Bonded Fiber Matrix, or rock rip rap)
- b. Establishment, irrigation and maintenance plan for permanent vegetation. Revegetation plans for all disturbed areas on the site in accordance with the vegetative practices section of this manual. Information provided by the engineer should include any of the following which are applicable:
  - Topsoil requirements,(see Standard Specification 601S.3.A, Salvaging and Placing Topsoil, as well as ECM 1.4.7
  - Seed, sod, and mulch type and rate of application (see 1.4. 7),
    - If seed is used to revegetate, include the soil retention blanket, FRM or BFM to be used until establishment
  - Irrigation schedule for permanent vegetative establishment,(see Special Specification for 609S)
  - Application technique,
  - Maintenance requirements for each specific area,
  - If vegetation is to be temporary,

- If vegetation is to be permanent,
- A clear definition of criteria to be utilized in determining when acceptable revegetation has taken place (minimum requirements are 95 percent coverage with no bare areas exceeding 16 square feet with a 1½ inch stand of grass).

Landscape installation and natural area restoration requirements may be applicable to certain developments. To find out what regulations may apply, an inquiry should be made to the Watershed Protection Department.

- c. Specific locations shall be noted for the following:
- Where special slope stabilization techniques are to be utilized and the extent of stabilization to be achieved.
  - Location and type of permanent Stormwater management facilities (e.g. detention ponds, water quality ponds, outlet protection/velocity dissipaters)
  - A schematic representation of each control measure for each phase of construction, with adequate specifications for the measure, such as dimensions and length (or size) and references to the City of Austin Standards and Standard Specifications, so that the feature can be built and maintained as intended.
  - For detention/sedimentation control devices, a summary of calculations for runoff from the ten (10) year storm (see section 1.4.2. of this manual). Calculations shall include velocity for each of the drainage sub basins to a control in the pre-disturbance, under construction, and permanently stabilized conditions.

**Section 5: Additional Considerations and Further Discussion on Submittal Requirements and Design Guidelines**

This section describes in more detail practices and BMPs noted above to guide the applicant in developing appropriate SWPPP submittals. The reviewers may require demonstration that the following have been considered:

**I. Site Management**

**Phasing** – Phasing is a preventive measure defined as: One portion of the site is disturbed at any one time to construct the infrastructure necessary to complete that phase. Subsequent phases are not started until earlier phases are substantially complete and exposed soils are stabilized. The plan reviewers will not allow a site plan to proceed without the applicant demonstrating that all feasible opportunities for phasing have been implemented. Construction sites greater than 25 acres are required to show phasing of disturbance tailored to the specific site conditions. Items that shall be considered to determine the effectiveness in phasing include: size of disturbed area, compatibility with construction sequence (e.g. Stormwater controls, then utilities, then roads, then pads), proximity to CEFs or waterways, slope

steepness. Sites less than 25 acres must demonstrate on the grading plan the areas to be disturbed and how it was minimized.

**Temporary Stabilization** – The construction sequence must indicate the length of time that phases will remain disturbed. The designer must anticipate the construction process and identify times when disturbed areas will be dormant (i.e. not making progress toward a benchmark phase) for 14 days or longer. These areas must be identified on the SWPPP and the temporary stabilization practices described. Inspectors will make note of length of time of dormant disturbed areas and require coverage on Day 15. Approved practices include: rock rip rap for concentrated flow areas and vehicle access; Flexible Growth Medium, Bonded Fiber Matrix, Turf Reinforcement Mat or Rolled Erosion Control Product for Slopes steeper than 4:1, and bark or wood chip mulch or sod for areas flatter than 4:1 slopes. Spoil piles will require daily cover or demonstration of adequate perimeter containment to prevent the migration of spoils outside of the defined spoil pile footprint. Unacceptable practices include broadcasting seed, paper based hydromulch, wood fiber based hydromulch without a tackifier. Inspectors will require invoice from applicator showing certification of mix as FRM or BFM. Inspectors have authority to require additional application of temporary stabilizer if visual inspection shows inadequate coverage.

No offsite flow can flow onto the Limits of Construction of the disturbed phase. SWPPP must show locations where pass-through flows may be safely diverted around disturbed areas and routed at a properly stabilized discharge point to downstream drainage conveyance. Proper stabilization shall be determined by the Environmental Inspector.

SWPPP must show all designated construction access points and equipment travel paths. In particular, if there are any CEFs, protected water ways or trees, the SWPPP must demonstrate that construction access is diverted at least 25 feet from such features. In addition to temporary stabilization measures for construction access, plans must demonstrate methods for ensuring that construction vehicles do not track sediment onto roadways.

Spoils may not be located in the 100 year flood plain, Critical Water Quality Zone, within 150 feet of a CEF or within 25 ft. of a concentrated flow path with more than 5 acres contributing drainage area

## **II. Drainage Control Points and Sediment Control BMPs**

Using the information gathered in the above analysis, the designer must determine the most practical and effective locations for controls to be installed. These controls should be located:

- As close to the source of sediment as possible, but sufficiently distant from areas under construction or from site traffic in order to avoid constant disturbance,
- In areas that permit access for maintenance to remove sediment build-up,

- Where they will not cause flooding of adjacent properties due to diversion or ponding of stormwater, and
- In areas where they will not be removed and replaced frequently.

### **III. Determining the Function of the Control**

The designer must determine which functional category of control (diversion, flow spreading, detention/filtration, or detention/sedimentation see 1.4.4 B2 *Design Guidelines*) will be appropriate at each location. In addition, the designer should be able to recognize which controls must be removed or relocated and which ones can remain in place throughout the entire construction period.

Using the base information developed previously, the designer can identify the location and function of controls and where phasing in the installation of controls is to occur. Phasing of the temporary controls is particularly important for construction projects that take significant periods of time to complete or where the construction work itself is divided into distinct phases. Such projects include major utility installations, large sites, and street and drainage improvements and subdivisions

Perimeter controls are placed at the edge of a project's disturbed area prior to the beginning of construction. All perimeters downslope from the construction site and any existing channels draining the site should be protected by temporary erosion and sedimentation controls. These control measures generally remain in place throughout the construction period since they are located outside the construction zone and should need only small adjustments. It should not be assumed that perimeter controls by themselves are adequate to control erosion and sedimentation. In all cases, perimeter controls shall be the secondary failsafe controls installed in conjunction with interior controls. For example, silt fence along the contours of the Limits of Construction (LOC) may be used as perimeter control in conjunction with interior controls such as site management practices, rock berms, mulch berms and sedimentation controls around spoils.

Interior controls are added inside the project perimeters during and after clearing, rough cut and fill operations when the site topography is rapidly changing. They are dynamic controls that, generally, must be modified to accommodate the changing conditions on the site in order to achieve optimum results. Examples of these types of controls would be temporary stabilization measures as outlined in previous sections, silt fence located below roadway fill sections, mulch berms on contour, protection of detention pond outlets and controls across backfilled utility trenches.

In addition, work in a channel that drains more than five acres shall employ a dewatering system that bypasses channel base flow around the site. At no time shall construction be permitted in any channel that does not have an approved bypass system. The most common and effective system consists of a temporary dam (not earthen) upstream of the construction site with a sump pump with the capacity to handle

the flow rate of the baseflow. Plans will need to show details of the berm/pump system to ensure pump/pipe capacity and that discharge is in a non-erosive manner downstream of the construction activity.

Where temporary channel crossings are required, compacted earth is not allowed. The designer must demonstrate that the proposed crossing is capable of withstanding a 25 year storm and that failure would not result in a discharge of construction materials.

#### **IV. Choosing the Control Device**

At this point the designer must determine which specific structural device will be effective at each location where control is needed. Choice of the specific control device for each location is dependent on the function to be accomplished (i.e. diversion, flow/spreading, or detention /sedimentation), the amount of flow, and the type of flow (i.e. sheet or concentrated flow) to be controlled. The designer may use any of the approved practices shown in this manual which are appropriate (see Figure 1-1 in Appendix V). [Figure 1-1.5](#) in Appendix V of this manual shows the example site plan with specific control devices, anticipated phasing, and associated runoff flow direction.

Sedimentation basins shall not be allowed as stand alone BMPs. Applicant must demonstrate appropriate site management practices, temporary stabilization measures, perimeter and internal controls instead of just relying on a sediment basin at the outlet of the project. Temporary sediment basins and traps are not allowed to be constructed where concentrated flow paths, draws, creeks or other drainage features exist that have contributing drainage areas greater than 10 acres.

Each control device must be able to function as designed when controlling the peak runoff resulting from the two (2) year, 24 hour storm. Flow calculations must be provided to reviewer and they should be based upon the methods presented in the City of Austin Drainage Criteria Manual. Calculations must assume a precondition of maximum allowable sediment accumulation. Therefore, the control devices must be designed for capacity of both the water flowing through as well as the sediment that could accumulate over normal operations. The designer must demonstrate that each device will be able to detain the water, , and contain the volume of sediment that may be mobilized during the 10 year storm (use Modified Universal Soil Loss Equation to quantify soil loss for 10 year storm). Mobilization includes sheet, rill and gully erosion as well as mass failures of cuts and stockpiles. Care must be taken to determine the location of any low points in control devices when assessing the flow capacity of the barrier. Table 1.4-A summarizes the characteristics of several typical temporary controls, including recommended maximum drainage area and maximum flow-through rate.

## Summary Check List

Upon completing the design of the temporary controls the engineer should check the design for compliance with the following list of guidelines:

- Control devices shall be located as close as possible to the source of sediment. They shall be situated to catch runoff prior to its entering drainage ways
- Controls shall be located approximately perpendicular to the direction of runoff flow for effective interception.
- Controls shall be used within their drainage acreage limits.
- Controls shaped to create detention areas shall have adequate space behind them for ponding of water and sediment accumulation including the volume of soil that can be transported by the 10 year, 24 hour storm (using MUSLE procedures).
- Perimeter controls shall be installed along the contour, if possible, to evenly spread the detained runoff. When their function is to divert water to another location, the control should gently slope downhill and the design shall include additional controls to slow velocity and prevent erosion along the flow path of the diversion.
- Detention controls that can not be installed along the contour shall have reinforced low points to protect against washouts from concentrated flow.
- Controls shall be located in areas that allow access for removal of sediment accumulations.
- Controls shall not be located in areas where they will be frequently disturbed during construction.
- Controls shall not be located where they will cause a flooding problem to adjacent property or rights-of-way.
- When controls must be removed to accommodate equipment, they shall be restored at the end of each working day.

It is recommended that the designer also review site management practices (as stated in 1.4.1.2 (B) in conjunction with the final temporary erosion and sedimentation control design

### **4. Permanent Erosion and Sedimentation Control.**

The design of effective permanent erosion and sedimentation controls and their installation as a part of the construction process is an obvious and necessary final step. Without adequate permanent controls, exposed or disturbed soil may erode, stream banks may become unstable, and sedimentation will occur in streams and lakes decreasing the recreational and aesthetic potential, reducing the diversity of plant and animal life, and potentially, threatening the quality of drinking water. Permanent controls include a broad range of items such as vegetation to hold soil in place, structures which cover the soil to protect it, and water quality improvement

devices (e.g. sedimentation/ filtration basins) which remove sediment once it is being carried by runoff.

Permanent controls shall be designed for less frequent (i.e. larger) storm flows than temporary controls, in order to maintain long-term effectiveness. The City of Austin Drainage Criteria Manual requires all drainage facilities, including channels, storm sewers inlets, detention ponds and water quality facilities, to be designed to intercept and transport runoff from a 25-year frequency storm. Flows greater than a 25-year frequency up to and including a 100-year frequency storm must be contained within defined rights-of-way or drainage easements. The project engineer, therefore, shall design these facilities such that velocities are below erosive values for the particular soil conditions and the 25 year 24 hour storm event, and that all structures can withstand the forces generated by the expected flows of the 25 year, 24 hour storm event. Likewise, on-site, privately owned drainage facilities and other areas subject to runoff shall be designed to withstand the maximum projected flows and velocities.

Permanent vegetation for minimizing erosion and sedimentation should be selected for its suitability in the general area, proposed land uses, and desired aesthetic, or landscaping, effect. In general, revegetation of disturbed areas using species of plants found naturally in the area of the site will have the best long-term success, especially in locations where care is likely to be minimal (e.g. in utility easements and road right-of-way). Using a mixture of grasses, forbs, shrubs and trees will maximize the ability of the vegetation to hold and protect the soil, by providing a variety of root structures at varying depths. Anytime that revegetation is achieved by seeding, it shall be accompanied by the appropriate soil retention blanket from Standard Specification 605 or with a FRM or BFM. Broadcasting of seed is not acceptable, nor is paper-based hydromulch or wood-fiber based with no tackifier acceptable. Additional information regarding revegetation can be found in Section 2, Landscape, and Section 5, Construction in Parks, in this Manual.

Care should be taken to avoid introducing aggressive species of non-native plants in sensitive environmental areas where they may supplant natives. Top soil imported from outside the site area often is source on undesirable weeds and grasses. See COA Standard Specifications 130S and 601S and 609S.

Similar to the design of temporary controls, the design of permanent facilities must assess the expected permanent drainage characteristics of the site. Factors to be investigated include:

- Patterns of flow on the site, including locations of sheet or channelized flow, with calculated depths and velocities.
- Off-site flows that must be passed through the site.
- Discharge characteristics of all proposed structures that intercept drainage - e.g. culverts, streets and drives, detention ponds, sedimentation/ filtration basins, storm sewers, etc.

With this information, the designer can determine the type and extent of permanent controls that will be required.

Where runoff is concentrated the engineer should attempt to return the flow to a sheet flow condition. This will generally result in much lower velocity with less erosion. In addition, flow will encourage vegetative filtration of the runoff to remove sediment and other pollutants, including those originating on adjacent impervious surfaces. When flow occurs over vegetated ground, the type of plants and their ability to withstand the expected velocity should be investigated.

If velocities are high, it should be determined if the rate of flow can be decreased without causing significant flooding. This might be done by reducing the slope, roughening the surface or modifying the shape of the channel. Where velocities are too high to permit vegetation, structural methods to protect the surface should be investigated. In general, the most "natural" technique should be used commensurate with the degree of protection needed and any risks involved - i.e. stone rip-rap would be preferable to concrete rip-rap; stacked stone walls would be preferred over formed concrete walls.

In those locations where it is feasible, flows should be released onto undisturbed well-vegetated areas. If it is necessary, permanent structural devices may be utilized to spread flow and reduce velocity.

Where flows are released into channels, erosion shall be prevented by assuring adequate vegetative cover, using appropriate protective materials or reducing velocity. Channel transitions, cuts, and fills without structural protection shall be smooth and natural to avoid unstable banks or slopes that might erode or collapse.

Whatever the site conditions, it is incumbent upon the designer to demonstrate to the reviewer, via accepted scientific and engineering methodology, that the permanent conditions are sufficient to withstand the erosive forces (shears and velocities) of the 25 year, 24 hour storm event. Use the DCM for acceptable calculations.

Good site management techniques will also benefit permanent erosion and sedimentation control. Proper land grading to achieve stable, maintainable slopes, the use of terraces in steeper cut areas, and vigorous stands of mixed vegetation (grasses, forbs, and trees) will retard stormwater flow, prevent erosion of soil, and capture sediment and pollutants from upslope areas.

Submittal requirement for permanent stabilization controls are the same as for the temporary construction phase controls. Refer to 1.4.4 (B).

- All detention, sedimentation, or sedimentation/filtration ponds.

### ***C. Plan Review Procedures.***

According to the Land Development Code, designs for erosion and sedimentation controls included with subdivision, site plan or site development permit applications will be reviewed by the Watershed Protection and Development Review Department. General criteria for review of plans are provided below. Reviewers shall not approve plans unless satisfied that the specific and general criteria provided in ECM 1.4 have been demonstrated and

certified by a Professional Engineer and Certified Professional in Erosion and Sedimentation Control (CPESC).

In addition, for all plans, the applicant must post fiscal surety, consisting of a letter-of-credit, cash, or a bond, for the cost of the erosion and sedimentation controls proposed for the site and the anticipated cost of clean-up of a sediment discharge as outlined in Appendix S. This money may be used by the city to provide controls, if the contractor does not properly install or maintain the temporary controls; it may be used to complete the revegetation of a site if the owner refuses or is unable to do so; it may be used to clean-up any on-site or off-site sediment spills that degrade public or private property if the contractor refuses to abide by the clean-up plan specified by the Watershed Protection and Development Review Department. This fiscal surety must be approved and accepted by the Watershed Protection and Development Review Department prior to final approval of the plans

#### ***D. Procedures During Construction.***

Proper installation, maintenance, and inspection of the approved control methods during the construction of a project are the final steps in assuring effective control of erosion and sedimentation. Implementation requires the combined efforts of the project engineer, contractor, owner, city inspectors, and, when needed, reviewers working together to achieve the best feasible control. The following sections highlight specific areas of individual and shared responsibility during the construction phase.

##### **1. Project Management.**

Knowledgeable and committed on-site management is important for the successful implementation of erosion and sedimentation controls, especially temporary control measures during construction. To accomplish this, it is required that the owner designate as “project manager” or “site supervisor” an on-site employee with certification as either a Certified Professional in Erosion and Sediment Control (CPESC) or Certified Erosion, Sediment and Stormwater Inspector (CESSWI) or CISEC who will be responsible for implementation of all erosion and sedimentation related requirements for the project (SWPPP). This certification requirement takes effect on October 4, 2010, in order to give the inspection community time for training and testing. The designated city inspector(s) responsible for the inspection and enforcement of erosion and sedimentation regulations can work with this individual to ensure that these requirements are met. The design engineer and the project manager working with a knowledgeable and involved city inspector will help to assure that effective controls are properly implemented and maintained.

##### **2. On-site Pre-construction Meeting**

Prior to the beginning of any development activities, the erosion/sedimentation controls (per the SWPPP) and tree and natural area protection specified in the approved plan must be in place. As required by Section 25-1-288 of the code, the owner will request the appropriate city department to schedule a preconstruction conference to assure that controls are in compliance with this manual and the approved plan and to correct any inadequacies in the plan that are identified during the

inspection. This inspection will be held within five (5) days of notification and will be attended by the permit holder, design engineer, SWPPP designer, contractor and representatives from all relevant city departments. No construction activities other than those required for installation of the erosion sedimentation control plan can proceed until this inspection is completed. Subsequent to this inspection and completion of any necessary corrections, the contractor may begin construction activity. At a minimum, the following items should be discussed at this meeting:

- The first phase of temporary controls (i.e. all perimeter controls installed at the edge of the disturbed area) and tree protection measures and all installation and maintenance specifications, adjustments, and additions (such as interior controls after rough cut and fill operations) necessary during upcoming stages of construction.
- The site management requirements for the project, including sequence of construction, phasing, temporary stabilization, temporary and permanent spoil disposal areas (on and off site), haul roads and site access, designated construction storage and staging areas, limits of clearing and disturbance, and requirements for construction in and around stream channels or other critical environmental areas.
- Permanent controls, such as detention and filtration ponds, related grading and drainage, revegetation schedule, seed mixes and special requirements.
- City inspection and inspection-related administrative procedures, such as duties and responsibilities of individual Departments' inspectors, coordination between inspectors, requirements for final project release, Certificates of Occupancy, etc.

At this stage the inspector should assure himself that the erosion and sedimentation control plan appears adequate. The following guidelines should be used in determining the adequacy of the plan:

- Controls should be located such that they will intercept and capture or divert the intended flow without bypassing runoff from the 2-year storm.
- All control devices should be used within specified contributing drainage acreage limits and in appropriate site applications.
- All disturbed areas that could cause sedimentation should be protected by at least one temporary control in addition to the Limits of Construction perimeter controls.
- All disturbed areas such as fills, steep slopes and channels must have control measures that will remain in place and trap sediment resulting from at least the two year storm.
- The plan must be adequately phased to be effective during all stages of construction.

In addition, it is recommended that the city inspector and other involved personnel inspect and note existing natural conditions adjacent to and downstream of the controls prior to construction. Reinspection of these

areas during construction can reveal evidence of disturbance or sedimentation resulting from inadequate control measures on the project.

### **3. Inspection by the Owner and Contractor.**

To assure continued effective operation of each methodology, the owner and/or engineer or certified inspector (CPESC or CESSWI) (hereafter referred to as owners representative) shall conduct ongoing inspections of all erosion/sedimentation controls and direct the person or firm responsible for maintenance to make any repairs or modifications necessary, within 48 hours of the initial notification. The owner's representative shall inspect the controls daily and keep on the job site an inspection log with updated entries at a minimum of once every 5 business days. Appendix P-5 contains a template of an acceptable inspection log. The log shall contain at a minimum the following information: date and time of inspection, recording of previous days weather conditions, including rainfall, a list of all controls and a map of the contributing sub-basins to each control; condition of controls for each sub-basin; required maintenance; date that maintenance was performed; construction sequence for temporary stabilization, phasing and movable BMPs. Signature of owner's representative. The City inspector shall have the right to request and review the inspection log at the job site.

Daily inspections shall be made by the contractor and silt accumulation upstream of temporary control measures must be removed when depth reaches six (6) inches. Prior to acceptance or approval of the project by the city, haul roads and waterway crossings constructed for temporary access must be removed, accumulated sediment removed from the waterway and any basins that will be used as permanent stormwater controls and the area returned to original grade and revegetated. All land clearing debris shall be disposed of prior to acceptance of the project by the city.

### **4. Compliance Inspection by the City.**

The Watershed Protection and Development Review Department is responsible for the inspection and enforcement of erosion and sedimentation control requirements on site developments. Subdivision inspection is the responsibility of the Department of Public Works, with support from the Watershed Protection and Development Review Department. The city will monitor compliance with plan requirements and judge the effectiveness of the controls during different stages of construction and before and after significant rainfall.

#### **Compliance Criteria**

The criteria used to determine the compliance or non-compliance of a project's temporary erosion and sedimentation controls include the following:

- The project must have a valid, current city development permit or site plan.
- The project must be in substantial compliance with the approved plans and specifications (SWPPP) for the development permit. This is determined by inspection of various items at the site.

Structural control practices which should be inspected are the following:

- Controls must be installed in all required areas in accordance with approved plans and specifications.
- Materials must meet minimum requirements.
- Maintenance must be performed when trapped sediment exceeds allowed limits.
- Disturbances by construction activity or runoff must be repaired within 48 hours of discovery (as determined by the inspection log or by the City Inspector).
- Temporary removal of portions of controls during necessary construction activities is allowed if the controls are replaced by the end of the work day. Additions or adjustments to the SWPPP are necessary if the controls cannot be replaced in their original location.

Site Management practices which should be reviewed include the following:

- Construction sequence and phasing must follow approved plans.
- Disturbed areas cannot exceed that shown on the approved plans, including fill areas, haul roads, and storage areas.
- All temporary and permanent spoil disposal areas, both on and off-site, must comply with approved plans and ordinances
  - All disturbed areas shall be temporarily stabilized during construction to prevent soil detachment from wind or rain.
- Construction in creek channels requires that upstream flows be impounded upstream of the work site and routed around the construction area anytime there is equipment in the channel. Spoils must be removed from the channel of any creek or drainage way and its associated floodplain at the end of each work day.

The installed controls must prevent sedimentation in off-site or undisturbed areas.

If the installed erosion and sedimentation controls are in compliance with the approved plans but are not adequate to prevent the transport of sediment from the disturbed areas, plan adjustments or a plan revision must be made. The inspector will not report the project as non-compliant in this situation (if it matches the approved plans), but will note on the inspection report that revisions are necessary.

### **Inspection Before and After Rainfall**

Controls and adjacent downstream areas should be carefully inspected just prior to expected significant (> one half inch) rainfall and inspected following significant rainfall events to assess the effectiveness of the controls and any adjustments, repair, or maintenance necessary. Inspection of the erosion and sedimentation controls this time is the most effective way to determine whether the plan is adequate.

The following guidelines can be used to determine the adequacy of controls after a rainfall:

- All visible drainage patterns left on-site after rainfall, especially areas of channelized flow (e.g. rills and gullies), should be carefully noted and the resulting effects of these on the structural controls should be observed. Concentrated flow areas, low points in perimeters, and channels adjacent to the project will usually be the critical areas where off-site sedimentation will be most likely to occur.
- Overtopping, undermining, or bypassing of the structural controls will require repairs, adjustments, relocation, or additional controls. Before taking these actions, determine if failures were due to inadequate installation, improper location, or greater runoff than the control was designed to handle.
- Above all, note where sediment has been carried on or off site. If controls appear to be intact and contain visible, significant amounts of sediment build up, this is evidence that they are working correctly. Visible amounts of sediment carried off of the project site is evidence that the temporary controls are not working as intended and that adjustments are needed. Any sediment carried off-site shall be retrieved by the contractor and returned to the site and stabilized. Any off-site damages that occur from fugitive sediment that exits a site shall be mitigated by the contractor per a mitigation plan approved by the COA Environmental Inspector. If contractor refuses to remediate, COA shall retain fiscal surety deposited to cover remediation.

The inspector and site personnel can recognize sediment that has been carried off of a particular project site by noting similarities in color, texture, and grain size to the soil existing on the site. It is recommended that existing off-site conditions be noted or documented before construction in order to help assess the effectiveness of the erosion and sedimentation controls during construction. Inspectors should also note the condition and operating characteristics of detention and water quality ponds under inspection after rainfall events in order to assess their performance prior to acceptance of a project.

### **Revisions to Controls**

Most erosion and sedimentation controls will normally require some minor adjustments or additions during construction. These are known as "field revisions" and will not require a plan revision if approved by the Engineer and the inspector. Significant modifications to the controls or the SWPPP, however, will require a plan revision and resubmittal to the Planning and Development Services Department for review by the Watershed Protection and Development Review Department.

### **Enforcement of Non-compliance by the City**

The city inspector responsible for environmental regulations can take enforcement action under Section 25-1-441 of the city's Land Development Code for non-compliance with erosion and sedimentation requirement on a project site. Enforcement action can be by way of the issuance of a Cease and Desist Order, that is, a Red Tag. Issuance of a Red Tag stops all city

inspection services and utility connections from all departments until the deficiencies are corrected and the Red Tag is released by the Watershed Protection and Development Review Department. Violations of environmental regulations may also be enforced by the city through the suspension of the site plan.

On projects that have obtained the required development permit/site plan from the city and where routine inspections reveal inadequacies in the controls, the inspector will give a verbal warning to the responsible personnel at the site of any noted and what corrective action is necessary. If, after a minimum period of 24 hours from this verbal warning, the deficiencies are not corrected, the inspector will deliver a written notice of non-compliance to the responsible on-site personnel and send a certified copy of this to the Owner, Design Engineer, and Contractor. If, after an additional minimum period of 24 hours, the deficiencies are not corrected, the inspector can issue a Red Tag to stop work on the project until the deficiencies are corrected.

If the temporary or permanent controls fail such that construction sediment evades the controls and migrates off the site, it shall be the responsibility of the Contractor to: 1) retrieve the fugitive sediment to the satisfaction of the City of Austin inspector 2) restore the off-site areas impacted by fugitive sediment to pre-disturbance conditions (determined by the City inspector, pre-disturbance photos and the impacted landowner(s));3) revise or repair erosion and sedimentation controls within 48 hours of failure to the satisfaction of City Inspector.

Enforcement action can proceed immediately without a 48-hour warning period by the city inspector in some situations. These include the following:

- Project is within the jurisdiction of the city but has started construction without obtaining the required development permit or site plan.
- Project has a valid permit but work was initiated without the required preconstruction meeting and without installation of temporary controls.
- When significant or irreparable damage is judged to be occurring on a permitted site, the inspector will first ask the contractor to cease all work in the area of the violation. Activities which may result in such damage are usually localized violations on a project site, such as removing a protected tree, disturbance near a critical environmental feature, or discharge of silt into a waterway. If the contractor complies with the verbal stop-work order and immediately institutes corrective measures in the area of the job violation, the inspector will not issue a Cease and Desist order. If the work in violation is not stopped and corrective measures are not taken, the inspector may issue a Cease and Desist Order for the entire project.

##### **5. Project Release or Acceptance by the City.**

Upon completion of the site construction and revegetation of a project site, the design engineer shall submit an engineer's letter of concurrence to the Watershed Protection and Development Review Department indicating that construction, including revegetation, is complete and in substantial

conformity with the approved plans. After receiving this letter, a final inspection will be scheduled by the appropriate city inspector.

As part of the final inspection, the city will inspect for the following environmental requirements:

- Determine that grass coverage and revegetation, including type of grasses, topsoil, temporary and permanent stabilization, are complete and in accordance with the plan requirements,
- Determine that all drainage facilities, including water quality facilities and permanent structural controls, are installed in accordance with the plans. Any water quality facilities with sediment deposits will not be accepted until the contractor cleans the facilities and re-installs the appropriate media such that it is per specifications of ECM 1.6.7.
- Note any unauthorized disturbance of the site or vegetation and ensure that all disturbed areas, including haul roads and spoil sites are revegetated.
- Determine that all special environmentally related requirements, such as replacement trees and buffer zone restoration, are complete.
- Note all temporary erosion and sedimentation control measures that will still be required due to incomplete revegetation. All controls and sediment must be removed upon the completion of revegetation and before the full fiscal deposit for erosion and sedimentation controls is released through the Watershed Protection and Development Review Department.

When all revegetation is completed as required by the plans and specifications the project can be certified for acceptance.

### **Developer's Contracts**

Section 25-8-181 of the Land Development Code requires that a separate and enforceable agreement to ensure revegetation be signed by the city and the developer of a project if maintenance responsibility for constructed facilities is accepted, or a temporary certificate of occupancy is issued, by the city before the required revegetation coverage is complete.

This agreement is in the form of a standard Developer's Contract in which the developer agrees to complete the required revegetation within a specified period of time, normally a 4-month period. The contract is tied to a fiscal surety in the form of a letter of credit, a cash deposit, or a bond. The amount of this fiscal surety is determined by the amount of disturbed area that will be required to be revegetated for the project. All areas disturbed as part of the project and any adjacent areas that were disturbed by the construction of the project will be required to be revegetated. The Contract states that if the required revegetation is not completed within the specified period of time, the city will use the deposited funds to ensure revegetation is completed.

The city can consider longer Developer's Contract periods for projects accomplishing revegetation with native grasses. The factors that will be considered for approval of longer revegetation periods than four months

will be: (a) the erosion and sedimentation potential of a particular project area which will be exposed to erosion for a longer period of time (temporary erosion and sedimentation measures must be constantly maintained until completion), (b) the use of only minimum amounts of topsoil to reduce erosion potential, (c) postponement of initial seeding until a more suitable seasonal time, (d) the good faith effort on the part of the developer/owner to accomplish project completion and revegetation as soon as practically possible.

Upon satisfactory completion of any outstanding items identified by the inspector, final release or acceptance of the project can occur.

***E. Failure to Complete a Project.***

***F. Maintenance Responsibilities After Construction.***

Following release or acceptance of a project (and termination of the development permit) the property owner is responsible for maintaining the project site. The release of excessive amounts of sediment in stormwater runoff is prohibited by the Storm Sewer and Watercourse Industrial Waste Discharge Ordinance. Any person causing stoppage, damage or restriction of flow in any storm sewer or watercourse may be liable to the city for repairs to these waterways.

***G. Additional Recommendations and Requirements for Selected Projects.***

It has been recognized that particular types of construction projects or projects in particular areas have common problems that are less frequently experienced in other circumstances. This section provides additional guidance for the engineer, reviewer, contractor, and inspector in order to better design, install and maintain effective temporary erosion and sedimentation controls.

**1. Major Utility Projects.**

Major water and waste water line installations can be challenging projects in which to accomplish effective temporary controls because of the limited working space and easements often involved. The location of waste water lines along creeks and in flood plains can create additional problems. Maintenance and access roads are frequently added after construction is complete, rather than being designed into the project.

Silt fence can be an effective perimeter control along the route of the pipeline. Rock berms and reinforced rock berms work well for concentrated flow. Hay bales dikes generally are not recommended for use. Triangular filter dikes can be used in short sections across the disturbed area. The triangular dikes must be placed such that the bottom of the dike is in full contact with the ground.

A two-phased plan should be implemented for these type of projects. Prior to construction, perimeter controls should be required parallel to the line installation and to provide protection at channels, spoil areas, and haul roads. These controls should not be directly disturbed by the trenching activity. In the second phase, after the pipe is installed and backfilled,

interior controls may be located perpendicular to or diagonally over the pipe installation area. These will control runoff and sediment in areas which do not drain into the parallel controls to the side. These controls are especially necessary on steep slopes which drain parallel to the line installation. These interior controls should be installed as soon after the backfilling of the trench as possible and should be situated to still allow access to the rest of the project by the contractor.

### **Site Management Practices**

Site management is crucial to the success of temporary erosion and sedimentation controls on this type of project. Especially important are temporary and permanent spoil disposal areas which must be adequate to handle the amount of material generated by the project, or the spoil material can overwhelm the easements, erosion controls, and tree protection.

Projects should follow the recommendations for construction adjacent to creeks and waterways and water discharges from construction sites discussed later in this section. This is especially true if any boring or tunneling operations will be performed as part of the job. In addition, there must be adequate access ways and haul roads approved for the project beforehand to allow access and equipment passage while keeping the limits of disturbance as small as possible.

Utility installations along or within existing paved roadways should follow the guidelines for protection of existing drainage facilities with temporary erosion and sedimentation controls.

### **2. Construction in Creeks and Channels (> 5 Acres).**

Projects in this category include some utilities, creek and channel improvements, regional detention ponds, bridges and culverts. In general, a two phase plan should be implemented for these drainage improvements. Construction in creek channels requires that upstream flows be impounded upstream of the work site and routed around the construction area anytime there is equipment in the channel. Spoils must be removed from the channel of any creek or drainage way and its associated floodplain at the end of each work day. It shall be the responsibility of the Engineer of Record or the SWPPP preparer to designate on the SWPPP and construction plans the method of dewatering the drainage feature. The SWPPP shall include the sequence of construction and the temporary and permanent stabilization of the drainage feature after disturbance. If significant areas adjacent to but above the channel are disturbed, silt fence should be installed parallel to the top of the bank to prevent from entering the waterway from the sides. All erosion and sedimentation controls for upland areas shall be located outside of concentrated flow paths. Bridge construction, which has localized impact on the channel, may require only a single phase plan with appropriate field adjustments. These silt fences should be adjusted as necessary as the bridge construction progresses.

When constructing detention ponds, a perimeter control, typically of silt fence, should be placed first along the downslope sides of the pond beyond the limits of the proposed grading work. After the pond is graded and the

outlet is complete, the silt fence should be adjusted such that it passes over the top of the outlet pipe on the outside of the pond. A semi-circular section of reinforced rock berm or silt fence can be added inside the pond at the outlet to improve sedimentation inside the pond. [Figure 1-1.6](#) in Appendix V of this manual indicates how these controls might be installed.

### **Site Management Practices**

Good site management practices are essential to the success of erosion and sedimentation controls for projects in larger waterways. Examples of several practices are provided below:

- **Fill Material Storage** - At the end of each work day the contractor should remove all loose excavated material from the channel and 100 year floodplain as delineated on the approved plan. No construction or fill materials can be stored within the limits of the channel or 100 year floodplain.
- **Temporary Creek Crossings** - Temporary crossings composed of soil may not be used.. They must be removed entirely from the stream bed as soon as possible.
- **Flow Across Construction Operations in a Channel** - Water-filled channels should always be de-watered if possible rather than attempting to conduct construction operations directly in them. This prevents the water from coming in contact with the disturbed soil and becoming silted. In larger channels de-watering can be done in one-half of the stream at a time. The design of dikes or berms to direct flow in channels should consider the possibility of these structures increasing flood levels during high flow conditions or eroding and contributing to increased downstream sedimentation. These structures and all associated construction should remain in the channel for the shortest time possible.
- **Dewatering or Diversion of Stream Flow** - The temporary damming and diversion (by pumping or gravity) of base flow around construction activities under way in a channel is required. This flow is then safely discharged further downstream and prevented from coming in contact with areas disturbed by the construction activity. Any time construction equipment or activity is placed in the channel, the flow at that time shall be diverted around the construction site and discharged in a non-erosive manner downstream of the channel construction. Sandbags are not an acceptable diversion structure in channels.
  - Stream flow that does become silted from construction activity must not be discharged directly back into the stream, but must be temporarily detained until the sediment has settled out. All water discharges should comply with the recommendations for Water Discharges from Construction Sites.
  - Bore Pit Locations - Bore pits should be located as far as possible from the main channel of any waterway. Bore pits located near stream beds greatly increase sedimentation into the waterway and are susceptible to frequent flooding.

- Frequent removal of sediment collected in treatment devices will reduce the risk of sediment release due to a sudden failure of an overloaded control

### **3. General Permit Utilities and Maintenance Activities.**

Work which is considered under permits for general utility installation and maintenance includes:

- Natural gas main service/repair for pipelines less than 200 feet in length.
- TV cable installation/repair within subdivisions and right-of-way.
- Telephone cable installation/repair within subdivisions and right-of-way.
- City of Austin water or waste water extensions less than 300 feet in length and routine and emergency repairs of existing facilities.
- City of Austin Parks Department installation, repair or landscaping of minor park facilities.
- City of Austin street and drainage maintenance and repair.
- City of Austin Electric Utility Department routine installation and maintenance of overhead electric distribution system facilities.

For small utilities projects, the two-phase erosion and sedimentation control plan used for major utilities can also be implemented. The first phase would include perimeter controls parallel to the line installation. The second phase would include interior controls installed perpendicular and diagonally over the trenched line after it is backfilled. Often, few temporary controls are necessary in flat areas for these types of small projects. Key areas for temporary control are roadside ditches or drainage swales, stream crossings, and steep slopes. Silt fences, rock berms, and small lengths of triangular filter dikes are recommended controls.

### **Site Management Practices**

For these projects, close on-site supervision and management of the fill material generated by the construction and timely removal of the excess spoil can often be more effective than temporary controls. In addition, appropriate protection of existing drainage facilities and revegetation after construction should be considered during design and installation phases.

### **4. Water Discharges from Construction Sites.**

A common erosion and sedimentation control problem other than stormwater runoff that can cause significant off-site sedimentation problems from construction sites is the discharge of silted water during certain construction operations. Title 6, Article V of the Austin City Code, entitled "Discharges to Storm Sewers and Watercourses", contains the minimum water quality compliance requirements for any water discharges into city storm sewers or waterways. Section 6-5-53 specifically includes water discharges from construction site excavations. Pump and Filter Press systems are acceptable and appropriate for removing sediment from water

prior to discharging into surface water or storm drain. Mobile filter presses that have capacity to remove up to -400 mesh particle size are recommended and acceptable.

The following list contains the five most common types of water discharges from construction sites that can cause significant off-site sedimentation problems and the recommended control techniques used in these situations.

**Boring or Tunneling Operations That Discharge Sediment Laden Water.**

All silted water and slurry generated by the construction can be pumped into one or more temporary earthen pits or metal tanks to allow the sediment to settle before discharging the clean water. These temporary sedimentation facilities must be adequately sized to be most effective and may be constructed in series to improve sediment removal.

**Groundwater or Channel Flow Seepage into Trenches or Excavations.**

Settling or removing of the silt laden water can be done as described in the item above. In addition, the work area can be de-watered by temporarily damming the flow and pumping the flow around the construction, to prevent it from entering the trench or excavation. Innovative or alternative methods, such as end-of-pipe socks, may also be proposed.

**Accumulated Stormwater in Trenches or Excavations After Rainfall.**

Recommended solutions are as described above.

**Flushing Water From Water and Wastewater Utility Lines or Storage Tanks.**

Prior to placing the utility lines in service, they must be flushed to remove accumulated debris or to sterilize the pipelines. If this water does not contain silt, use a hose extension to allow the water to be discharged to an undisturbed, vegetated area. Discharging clean water over an unvegetated area may create an erosion and sedimentation problem if velocities are high enough to erode the disturbed earth. If the water to be discharged contains silt, it should be treated using the techniques described above: detention/ sedimentation or removal off-site.

**5. Protection of Existing Drainage Facilities.**

Construction projects located in or adjacent to developed areas with existing drainage facilities often require partial protection of these drainage facilities for effective erosion and sedimentation control. This must be done in a manner that will effectively trap sediment without impeding the stormwater drainage flow and function of the facility. Inlets should never be completely sealed.

**Curb Inlets.** (See 1.4.5P)

**Area Inlets.**

Surround the inlet with reinforced silt fencing. Sediment will be trapped mainly by detention/ sedimentation with some filtration.

**Detention Pond Outlets.**

Reinforced rock berms or reinforced silt fencing should be placed around the outlet on the inside of the pond to enhance sedimentation, especially during low flow events and when the pond is not fully revegetated. Temporary controls preferably should be placed inside the pond outlet rather than outside. If placed outside, a semicircular rock berm or reinforced rock berm should be placed immediately below the outlet headwall.

## 1.4.5 Temporary Structural Practices

### A. *Mulching*

#### 1. Description.

Mulching is the process of applying wood mulch, wood chips, or other organic material to the exposed soil surface to protect it from erosive forces (wind, water, etc.) and to conserve soil moisture until plants can become established. Mulching shall not be considered a primary erosion control, but shall be used in conjunction with other approved controls.

The effectiveness of using Mulching as an erosion control technique depends on:

- The type of mulch used
- Mulch morphology
- Application rate
- Method of application: the mulching material can be placed mechanically or by hand.
- Soil type
- Slope
- Climatic characteristics
- Proper preparation of application area (uniform application surface to ensure optimal mulch to soil contact)

#### 2. Materials.

Mulching material can be manufactured on or off the project site. It consists primarily of organic material, separated at the point of generation, and may include: shredded bark, stump grindings, or composted bark

The mulching shall have the following composition:

- Use wood chips produced from a 3 (three) inch minus screening process (equivalent to TXDOT Item 161 Section 1.6.2.B Wood Chip requirements).
- Large portions of silts, clays, or fine sands are not acceptable in the mix.
- The pH should fall between 5.5 and 8.5.
- The organic matter content is  $\geq 25\%$ , dry weight basis.

Mulching material is composed of a well-graded mixture of particle sizes and may contain rocks less than 2" in diameter. Mulching material must be free of refuse, physical contaminants, and material toxic to plant growth. It is not acceptable for the mulching material to contain ground construction debris, biosolids, or manure.

Prior to placement a representative sample of the mulching material must be tested and certified by the project engineer or his/her designee and accepted by the city inspector.

### **3. Installation.**

Mulching is performed after grading and soil surface preparation is completed.

- Mulching is not allowed on 2:1 slopes or steeper.
- Mulching on slopes of 3:1 or flatter use a minimum depth of 4 inches. Apply mulching material a minimum of three (3) feet over the shoulder and beyond the base of the slope or into existing vegetation where possible to prevent rill formation and transport of the material (Figure 1.4-A).
- The mulch may be placed with a hydraulic bucket, a pneumatic blower, or by hand.
- The effectiveness of the mulching material depends on good contact between the soil and mulching material. Maximum contact with the soil promotes increased infiltration and sediment trap formations. If the mulching material does not make full contact with the soil, is perched above the soil by clods, or stays suspended above depressed areas, severe rill erosion can occur beneath it. Therefore mulching material must be placed to ensure maximum contact with the soil. Provide a smooth application surface by tracking, rolling, raking, etc. to ensure an optimal mulch to soil contact.
- The mulching material shall be placed evenly and uniformly to provide 100 % coverage.

### **4. Where mulching is not allowed as an erosion control:**

- On slopes with groundwater seepage;
- At low points with concentrated flows and in gullies;
- On slopes equal to or steeper than 2:1;
- At the bottom of steep perimeter slopes exceeding 100 feet in length (large up-gradient watershed);
- Below culvert outlet aprons, and
- Around catch basins and closed storm system outlets.
- Within a stormwater control structure.
- No mulching material shall be placed within 100 feet of any source of surface water or drinking water supply.

- Mulching shall not be used as a primary perimeter site erosion control.

#### **5. Inspection and Maintenance.**

- The mulched area shall be inspected regularly and after each large rainfall. Any required repairs shall be made immediately, with additional mulching material placed on top of the mulch to reach the recommended thickness.
- When the mix is decomposed, clogged with sediment, eroded or ineffective, it must be replaced or repaired.
- Vegetation adds stability and should be promoted.
- If the mulch is not removed prior to revegetation, it should be spread out into the landscape to a depth that will not prevent seed germination and will encourage effective revegetation of the site.

#### **References:**

Foltz, Dooley (2003), Comparison of Erosion Reduction Between Wood Strand and Agricultural Straw, *Trans. ASAE* 46(5): 1389-1396.

Demars, Long, and Ives (2000), Use of Wood Waste Materials for Erosion Control, NETCR 20

McCoy and Noble (2002), Use of Compost & Mulch for Storm Water Management, Erosion & Sediment Control, TCEQ

Wischmeier, W.H. and D.D. Smith (1978), "Predicting Rainfall Erosion Losses – A Guide to Conservation Planning" U.S. Department of Agriculture, Agriculture Handbook No. 537

**NOTE:** The following figure is not a primary erosion control and should be used in conjunction with mulch socks, silt fences, mulch berms, and other approved methods of sedimentation and erosion control.

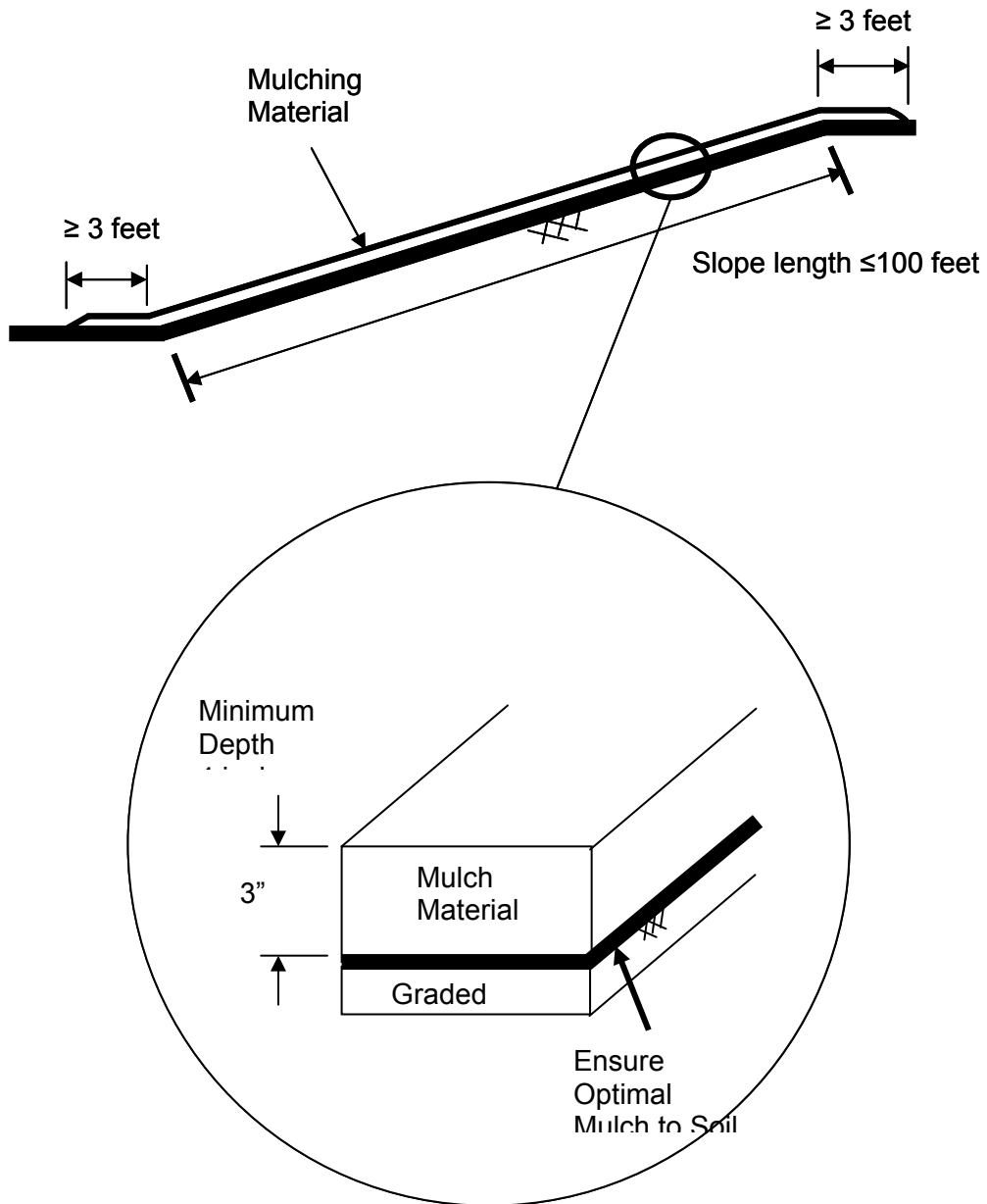

**Figure 1.4-A Mulching Detail**

***B. Diversion, Interceptor and Perimeter Dikes.***

(See [Figure 1-3](#) in Standard Specifications manual items 622S, 630S, and 635S and Specifications manual items 622S-1, 630S-1, and 635S-1 respectively for detail.)

### **1. Definition.**

A temporary ridge of compacted soil located either (1) immediately above cut or fill slopes, (2) across disturbed areas or rights of way or (3) along the perimeter of the site or disturbed areas.

### **2. Purpose.**

- A diversion dike intercepts runoff from small upland areas and diverts it away from exposed slopes to a stabilized outlet, such as a rock berm, brush berm or stone outlet structure.
- An interceptor dike shortens the length of exposed slopes by intercepting runoff and diverting it to a stabilized outlet.
- A perimeter dike prevents off-site runoff from entering the disturbed area and prevents sediment laden storm runoff from leaving the construction-site or disturbed area.

### **3. Conditions Where Practice Applies.**

Dikes are generally used for the period of construction to intercept and reroute runoff around disturbed areas to prevent excessive erosion until permanent drainage features are installed and/or slopes are stabilized. The repose characteristics of the material of construction should be considered for installations on steep slopes.

### **4. Design Criteria.**

The following criteria shall be observed.

- Drainage Area - Less than five (5) acres (recommended)
- Top Width - Two (2) feet minimum
- Height (compacted fill) - 18 inches minimum height measured from the top of the existing ground at the upslope toe to top of the dike
- Side Slopes - 2:1 or flatter
- Stabilization - Where slope of channel is one (1) to five (5) percent, stabilization is required if velocity exceeds one (1) foot per second; over five (5) percent, stabilization shall be required.
- Stabilization, when required, shall be demonstrated to prevent erosion up to the 25 year 24 hour storm flow.
- Spacing.
- Slope of disturbed areas above dike: greater than 10%, 5-10%, less than 5%.
- Maximum distance between dikes: 100 ft., 200 ft., 300 ft.

### **5. Outlet.**

- Diverted runoff from a protected or stabilized area shall outfall directly to an undisturbed stabilized area or into a level spreader (see Section [1.4.3 C](#)) or grade stabilization structure (see Section [1.4.3 H](#)).

- Diverted runoff from a disturbed or exposed upland area shall be conveyed to a sediment trapping device such as a rock berm, brush berm, stone outlet structure, sediment trap or sediment basin or to an area protected by any of these practices.

**C. *Interceptor and Perimeter Swales.***

(See Standard Specifications manual items 631S and 636S and Specifications manual items 631S-1 and 636S-1 for detail)

**1. Definition.**

A temporary excavated drainageway located across disturbed areas or rights of way or along the perimeter of a construction site.

**2. Purpose.**

Interceptor swales shorten the length of exposed slope by intercepting runoff. Perimeter swales prevent off-site runoff from entering the disturbed area or prevent sediment-laden runoff from leaving the construction site or disturbed area. The outflow from a swale must be directed to a stabilized outlet or sediment trapping device.

**3. Conditions Where Practice Applies.**

Interceptor swales are constructed across disturbed easements/ rights of way, such as for utility cuts and streets or disturbed areas such as graded parking lots or land fills. The perimeter swale is used for the period of construction at the perimeter of the disturbed area. The perimeter swale also is used to prevent storm runoff from entering the disturbed area.

This runoff shall be adequately handled to prevent damage due to flooding or erosion to adjacent property. Swales shall remain in place until the disturbed area is permanently stabilized.

**4. Design Criteria.**

The following criteria shall be observed.

- Drainage Area – Less than five (5) acres (recommended)
- Top Width – Four (4) feet minimum and the bottom shall be level.
- Depth – One (1) foot minimum
- Side Slopes – 2:1 or flatter
- Grade – One (1) to three (3) percent; must have positive drainage (sufficient grade to drain) to an adequate outlet.
- Stabilization – Where slope of channel is one (1) to five (5) percent, stabilization is required if velocity exceeds one (1) foot per second; over five (5) percent, stabilization shall be required.
- Stabilization – When required, shall demonstrate that erosion is prevented for up to the 2 year 24 hour storm flow.
- Traffic Crossings – all points where vehicles will cross swales must be stabilized as above, except the stone lining shall be at least six (6) inches in thickness for the full width of the traffic crossing.

- Spacing
- Slope of right of way or disturbed area: greater than 10%. 5-10%, less than 5%.
- Minimum distance: 100 ft., 200 ft., 300 ft.

#### **5. Outlet.**

- Diverted runoff from a protected or stabilized upland area shall outlet directly onto an undisturbed stabilized area, level spreader or into a grade stabilization structure.
- Diverted runoff from a disturbed or exposed upland area shall be conveyed to a sediment trapping device, such as a rock berm, brush berm, stone outlet structure, sediment trap or sediment basin or to an area protected by any of these practices.
- The on-site location of the swale may need to be adjusted to meet field conditions in order to utilize the most suitable outlet.

#### **D. Stone Outlet Structures.**

(See Standard Specifications manual item 643S and Specifications manual item 643S-1 for detail.)

##### **1. Definition.**

A temporary crushed stone dike installed in conjunction with and as a part of a diversion dike, interceptor dike or perimeter dike.

##### **2. Purpose.**

The purpose of the stone outlet structure is to provide a protected outlet for a diversion dike, interceptor dike or perimeter dike to provide for diffusion of concentrated flow and to allow the area behind the dike to dewater.

##### **3. Conditions Where Practice Applies.**

Stone outlet structures apply to any point of discharge where there is need to dispose of runoff at a protected outlet or to diffuse concentrated flow for the duration of the period of construction.

##### **4. Design Criteria.**

The drainage area above the structure is recommended to be less than five (5) acres. The minimum length, in feet, of the crest of the stone outlet structure shall be equal to six (6) times the number of acres of contributing drainage area. Maximum allowable flow through rate is 40 gallons per minute per foot squared. The crest of the stone dike shall be at least six (6) inches lower than the lowest elevation of the top of the earth dike and shall be level. The stone shall be crushed stone. Unless otherwise specified, all aggregate used in a stone outlet structure shall be three (3) to five (5) inches open graded rock or larger. A fabric core consisting of geotextile wrapped stone having a minimum diameter of one (1) foot shall be incorporated into the structure. The stone outlet structure shall be located so as to discharge onto an already stabilized area or into a stable

watercourse. Stabilization shall consist of complete vegetative cover, paving, etc., sufficiently established to be erosion resistant.

Fabric core specification shall be nonwoven polypropylene, polyethylene or polyamide geotextile, minimum unit weight 4-½ ounces per square yard, mullen burst strength exceeding 250 pounds per square inch, ultraviolet stability exceeding 70 percent and equivalent opening size exceeding 40.

## **5. Maintenance.**

The area upstream from the stone outlet structure shall be maintained in a condition which will allow sediment to be removed following the runoff of a rainfall event. Periodic inspections (after each rainfall) shall be made by the contractor and when the silt reaches a depth equal to 1/3 the height of the structure or one (1) foot, whichever is less, accumulated silt shall be removed and disposed of at an approved site in a manner that will not contribute to additional siltation. The structure shall be reshaped as needed during inspection. The structure shall be left in place until all upstream areas are stabilized and accumulated silt is removed.

## **E. Rock Berm.**

(See Standard Specifications manual item 639S and Specifications manual item 639S-1 for detail)

### **1. Description.**

A temporary berm constructed of open graded rock installed at the toe of a slope or the perimeter of a developing or disturbed area.

### **2. Purpose.**

The purpose of a rock berm is to intercept sediment-laden water from unprotected areas, detain the sediment and release the water in sheet flow.

### **3. Conditions Where Practice Applies.**

The rock berm is used where:

- There is sheet flow or concentration of water in a channel or other drainageway above the berm.
- The contributing drainage area is generally less than five (5) acres.

### **4. Design Criteria.**

A rock berm is constructed at the perimeter of a disturbed site within the developing area. It is not to be constructed outside the property lines without obtaining a legal easement from the affected adjacent property owners.

The following criteria shall be observed.

- **Drainage Area** - Less than five (5) acres (recommended)
- **Maximum Flow Through Rate** - 60 gallons per minute per foot squared
- **Height** - 18 inches minimum height measured from the top of the existing ground at the upslope toe to top of the berm.

- **Top Width** - Two (2) foot minimum
- **Side Slopes** - 2:1 or flatter
- **Woven Wire Sheathing** - Hexagonal opening hardware netting (such as poultry netting) secured with hog rings.

Width = as required

Wire = 20 gauge, galvanized

Opening = Hexagon, one (1) inch in diameter

Woven wire sheathing is required when there is concentration of water above the berm. For severe service (in stream use) the sheathing must be secured or staked to the stream bed.

- **Grade** - Berms will be built along the contour at zero (0) percent grade or as near as possible.
- **Material** - Open graded rock three (3) to five (5) inches diameter (for sheet flow or concentrated flow condition).

Open graded rock four (4) to eight (8) inches diameter (for sewer service - in stream use).

## **5. Outlet.**

Runoff shall outfall directly to an undisturbed stabilized area.

## **6. Maintenance.**

The area upstream from the rock berm shall be maintained in a condition which will allow sediment to be removed following the runoff of a rainfall event. Weekly or after each rainfall, inspection shall be made by the responsible party and when the silt reaches a depth equal to 1/3 the height of the berm or one (1) foot, whichever is less, it shall be removed and the accumulated silt disposed of at an approved site in a manner that will not contribute to additional siltation

## **F. Mulch Socks.**

### **1. Description.**

A mulch sock is mulch material encased in mesh to form a tube/roll. A technique used to intercept sheet flow and pond runoff, allowing sediment to fall out of suspension, and often filtering sediment as well. Mulch socks provide an environmentally-sensitive and cost-effective alternative to sediment fence.

### **2. Material.**

Mulching material can be manufactured on or off the project site. It consists primarily of organic material, separated at the point of generation, and may include: shredded bark, stump grindings, or composted bark.

The mulch shall have the following composition:

- Use wood chips produced from a 3 (three) inch minus screening process (equivalent to TXDOT Item 161, Compost, Section 1.6.2.B, Wood Chip requirements).
- Large portions of silts, clays, or fine sands are not acceptable in the mix.
- The pH should fall between 5.5 and 8.5.
- The organic matter content is  $\geq 25\%$ , dry weight basis.

Mulch material must be free of refuse, physical contaminants, and material toxic to plant growth. It is not acceptable for the mulch material to contain ground construction debris, biosolids, or manure.

Sock material will be 100% biodegradable, photodegradable, or recyclable such as burlap, twine, UV photodegradable plastic, polyester, or any other acceptable material.

Prior to placement, a representative sample of the mulching material must be tested and certified by the project engineer or his/her designee and accepted by the city inspector.

### **3. Installation.**

- Use 12 or 18 inch diameter mulch socks for all sediment control applications. The 18 inch diameter sock material has proven to be the most consistent for all sediment control applications (TxDOT, April 2006).
- Mulch socks should be used at the base of slopes no steeper than 2:1 and should not exceed the maximum spacing criteria provide in Table 1.4-A for a given slope category.
- Place mulch socks at a 5' or greater distance away from the toe of slopes to maximize space available for sediment deposition.
- When placed on level contours sheet flow of water should be perpendicular to the mulch sock at impact and un-concentrated.
- Install mulch socks using rebar stakes with a minimum 3/8 inch diameter and a minimum length of 48-inches or wood stakes with a minimum dimensions of 1 inch by 2 inch and a minimum length of 48 inches, placed behind the mulch sock on 2-foot centers. Drive the stakes in the ground to a minimum depth of 24-inches leaving less than 12-inches of post above the exposed mulch socks. It is preferable to cut the post flush with the top of the mulch sock.
- In order to prevent the movement or floating of the mulch log during rain events or construction operations, install stakes on the front side placed on 2-foot centers.
- In order to prevent water flowing around the ends of mulch socks, point the ends upslope to place them at a higher elevation.
- In order to prevent water flowing between the gaps between the joints of adjacent ends of mulch socks lap the ends of adjacent mulch socks

a minimum of 12 inches. Never stack mulch socks on top of one another.

- Mulch socks can be placed around the perimeter of affected areas, if the area is flat or the perimeter is on contour. Socks should be placed using 'smiles' and j-hooks (see section 1.4.5.G., Silt Fence for proper placement and J hook details.)
- Do not place socks where they cannot pond water.
- For steeper slopes, an additional sock can be constructed on the top of the slope and within the slope area as determined by specific field conditions. Multiple socks are recommended on steeper slopes.
- Do not use mulch socks in areas of concentrated flow, as they are intended to control sheet flow only.

#### **4. Where a mulch socks are not allowed as a sediment control:**

- On slopes with groundwater seepage;
- In concentrated flow situations or in runoff channels;
- On slopes equal to or steeper than 2:1;
- At the bottom of steep perimeter slopes exceeding 250 feet in length (large up-gradient watershed);
- Below culvert outlet aprons, and
- Around catch basins and closed storm system outlets.
- Within a stormwater control structure.

#### **5. Inspection and Maintenance**

- Inspect mulch socks after installation for gaps under the mulch socks and for gaps between the joints of adjacent ends of mulch socks.
- Inspect every 7-days and within 24-hours of a rainfall event of 0.5-inches or greater event and replace or repair if necessary.
- Sediment retained by the sock shall be removed when it has reached 1/3 of the exposed height of the sock. Alternatively, the sediment and sock can be stabilized with vegetation at the end of construction.
- Mulch socks can be vegetated or unvegetated. Vegetated mulch socks can be left in place. The vegetation grows into the slope, further anchoring the filter sock. Unvegetated filter socks are often cut open when the project is completed, and the mulch is spread around the site as soil amendment. The mulch should be spread out into the landscape to a depth that will not prevent seed germination and encourage effective revegetation of the site.

#### **References**

Demars, Long, and Ives (2001), Performance Specifications for Wood Waste Materials As An Erosion Control Mulch And As A Filter Berm, NETCR 25

City of Austin, Mabel Davis Park Site Remediation, Standard Technical Specifications, Compost/Mulch Filter Berm - Section 02273 (2004), Volume 2

Storey, et al. (2006), Water Quality Characteristics and Performance of Compost Filter Berms, Report 0-4572-1, Texas Department of Transportation

**Table 1.4-A Mulch Sock Slopes, Maximum Slope Lengths, and Sock Diameters**

Slope	Max. Slope Length Between 18 inch diameter Socks (feet)	Max. Slope Length Between 12 inch diameter Socks (feet)
100:1-50:1	100	100
50:1-30:1	75	40
30:1-25:1	65	30
25:1-20:1	50	25
20:1-10:1	25	15
10:1-5:1	15	10
5:1-2:1	10	5

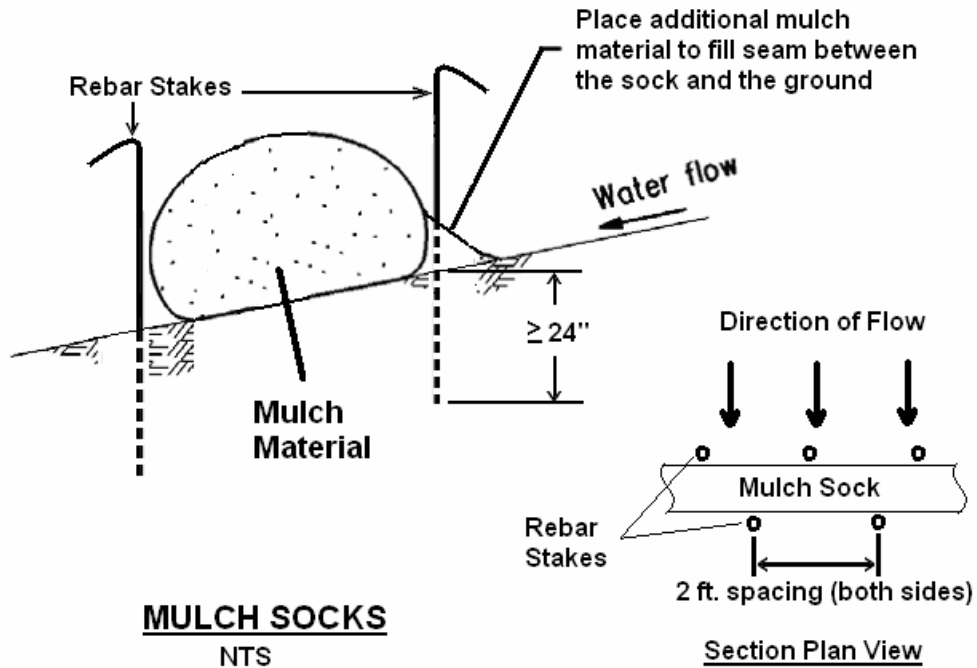

## Figure 1.4-B Typical Mulch Sock Detail

### G. Silt Fence.

(See Standard Specifications manual item 642S for details)

#### 1. Description.

Silt Fence is a temporary barrier made of non-woven polypropylene, polyethylene, or polyamide material that is trenched or sliced into the ground and supported by posts on the downstream side of the fabric. Silt fence works by intercepting sheet flow from slopes, causing the runoff to pond behind the fence, thereby promoting deposition of sediment on the uphill side of the fence. They are most effective when designed to provide comprehensive water and sediment control throughout a construction site and if used in conjunction with erosion control practices.

A common misconception among many designers is that the silt fence actually “filters” suspended particles from runoff. The effectiveness of silt fence is primarily derived from its ability to pond water behind the fence. This ponding action allows suspended particles to settle out on the uphill side of the fence. Particles are not removed by filtering the runoff through the fabric.

#### 2. Purpose.

Used to control sheet flow runoff from disturbed land, silt fencing may also be used to create a sediment trap for removal of suspended particles from low volume concentrated flows. The removal efficiency of silt fencing depends mainly on the detention time of the runoff behind the control. The detention time is controlled by the geometry of the upstream pond, hydraulic properties of the fabric, and maintenance of the control (Barrett et al., 1998).

#### 3. Conditions Where Practice Applies.

Silt fence is used during the period of construction near the perimeter of a disturbed area to intercept sediment. This fence shall remain in place until the disturbed area is permanently stabilized. Silt fence should not be used where there is a concentration of water in a channel or drainage way or where soil conditions prevent a minimum toe-in depth of six (6) inches or installation of support post to a minimum depth of 12 inches. If concentrated flow occurs after installation, corrective action must be taken such as placing rock berms in the areas of concentrated flow.

#### 4. Design Criteria.

Silt fence is typically constructed near the perimeter of a disturbed site within the developing area. It is not to be constructed outside the property lines without obtaining a legal easement from the affected adjacent property owners.

The following criteria shall be observed:

- **Drainage Area** - Consult Table 1.4-B for maximum drainage area allowed for a specific slope category. If the drainage area to the silt

fence exceeds this value, additional silt fence should be installed to break up the runoff into multiple storage areas.

- **Maximum Flow Through Rate** - 40 gallons per minute per foot squared frontal area.
- **Height** - 24 inch minimum height measured from the existing or graded ground.

For Design purposes use the following criteria:

- Assume a construction Total Suspended Solids (TSS) concentration = 3000 mg/L
- Use a target removal of sediment particle equal to or greater than diameter (d) = 20 microns.
- Use the Influent Particle size distribution of the solids suspended in runoff shown in Figure 1.4-C (Barrett et al., 1998)

a. **Overland flow.**

**General guidelines.**

Silt fence for sediment and slope control should be installed along the contour of the slope (i.e. the entire length should be at the same elevation). The maximum drainage area to the silt fence should not exceed those shown on Table 1.4-B. At each end of the silt fence, a minimum 20-foot segment shall be turned uphill to create a “J” hook (see “J”-hook detail) to prevent ponded water from flowing around the ends of the silt fence. Individual sections of silt fence should be limited to 200-foot lengths. This limits the impact if a failure occurs, and prevents large volumes of water from accumulating and flowing to one end of the installation, which may cause damage to the fence.

**Sediment control.**

When used for sediment control, silt fence should be located to provide the storage volume behind the fence that will contain the runoff from the 2 year storm. Table 1.4-B provides the spacing on uniform slopes necessary to achieve this storage volume. If the designer proposed an alternative configuration, it must be demonstrated that 2 year storm runoff volume is contained and released in a manner such that the effluent concentration does not exceed effluent standards of City of Austin Code Title 6, Article 5 as well as the baseline TSS conditions in ECM 1.6.9.3 Table 1-10. The design presumptions are stated above.

Larger storage volumes increase the sediment removal efficiency of the silt fence, and decrease the required replacement/clean-out intervals.

A common location to place silt fence for sediment control is at the toe of a slope. When used for this application, the silt fence should be located at least five (5) feet from the toe of the slope to ensure that a large storage volume is available for runoff and sediment.

For sediment control applications, the maximum drainage area to the silt fence should not exceed those shown on Table 1.4-B. If the contributing area exceeds this value, additional silt fence should be installed to break up the runoff into multiple storage areas. When used as a velocity control measure for sheet flow on long slopes of disturbed ground, silt fence should be placed at the spacing interval and not exceed the drainage area to the fence stated in the table below:

**Slope control.**

Silt fence can be installed on a slope to reduce the effective slope length and limit the velocity of runoff flowing down the slope (see the following table). Silt fence also helps prevent concentrated flows from developing, which can cause rill and gully erosion. As a secondary benefit, silt fence installed on slopes can remove suspended sediment from runoff that results from any erosion that has occurred. For slopes that receive runoff from above, a silt fence should be placed at the top of the slope to control the velocity of the flow running onto the slope, and to spread the runoff out into sheet flow.

**Table 1.4-B Maximum spacing between silt fences on slopes**

Slope	Spacing Interval (ft)	Max. Drainage Area (SF)
100:1 to 50:1 (1-2%)	500	25,000
50:1 to 30:1 (2-3.3%)	250	15,000
30:1 to 25:1 (3.3-4%)	150	12,000
25:1 to 20:1 (4-5%)	120	10,000
20:1 to 10:1 (5-10%)	100	5,000
10:1 to 5:1 (10-20%)	50	2,500
5:1 to 2:1 (20-50%)	10	1,000

**Perimeter control.**

Silt fence is commonly used as a perimeter control along streets or adjacent to water bodies to prevent polluted water from leaving the site. When a diversion or perimeter control silt fence is installed in the direction of a slope, a 20-foot length of fence should be turned in, across the slope, at regular intervals (100 feet) to create a “J”-hook (see “J” hook detail).

These “J”-hooks act as check dams, controlling the velocity of the diverted runoff as it travels along the fence.

**b. Concentrated flow.**

Not allowed

**c. Diversion.**

Silt fence can also be utilized as a synthetic diversion structure to redirect clean water around a site and intercept sediment-laden runoff and transport it to a sediment removal practice. Must demonstrate additional BMPs designed to prevent rill/gully erosion due to concentrated flow along the perimeter of the silt fence.

**5. Materials Specifications.**

(See City of Austin Standard Specifications 642S for material specification and installation details.)

**6. Troubleshooting**

- Inspect BMPs prior to forecast rain, daily during extended rain events, after rain events, weekly during the rainy season, and at two-week intervals during the non-rainy season.
- Repair undercut silt fences.
- Repair or replace split, torn, slumping, or weathered fabric. The lifespan of silt fence fabric is generally 5 to 8 months.
- Silt fences that are damaged and become unsuitable for the intended purpose should be removed from the site of work, disposed of, and replaced with new silt fence barriers.
- Sediment that accumulates in the silt fence must be periodically removed in order to maintain silt fence effectiveness. Sediment should be removed when the sediment accumulation reaches approximately one-half of the fence height (one foot) on the silt fence. Sediment removed during maintenance may be incorporated into earthwork on the site or disposed at an appropriate location. Upon removal of silt fence, accumulated sediment must also be removed and disposed of properly.
- Silt fences should be left in place until the upstream area is permanently stabilized. Until then, the silt fence must be inspected and maintained.
- Holes, depressions, or other ground disturbance caused by the removal of the silt fences should be backfilled and repaired.

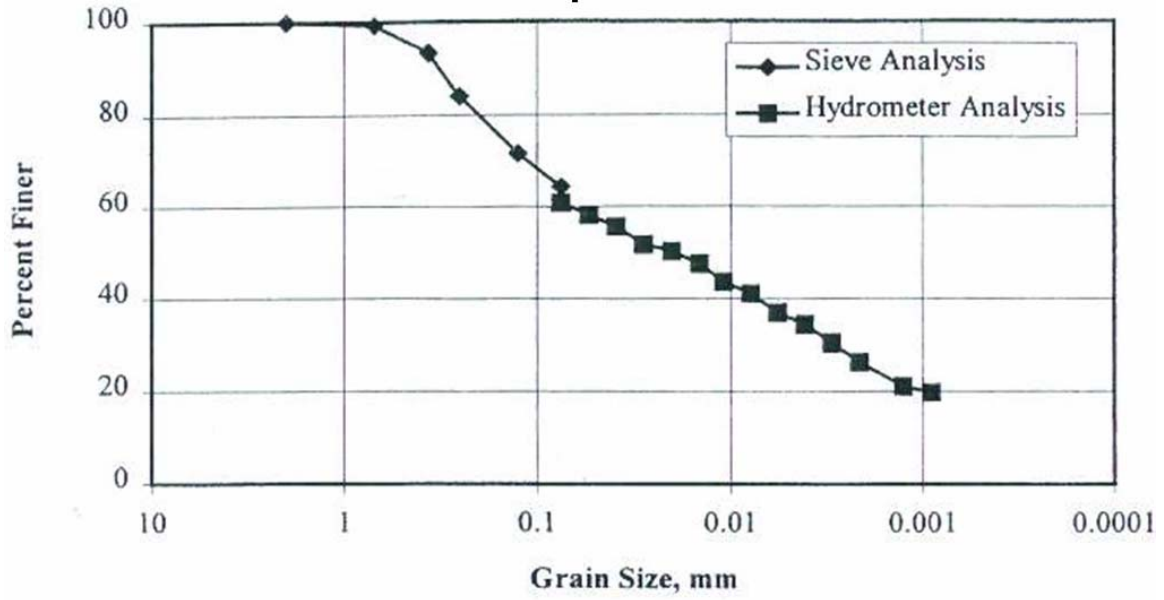

Figure 1.4-C Influent Particle Size Distribution

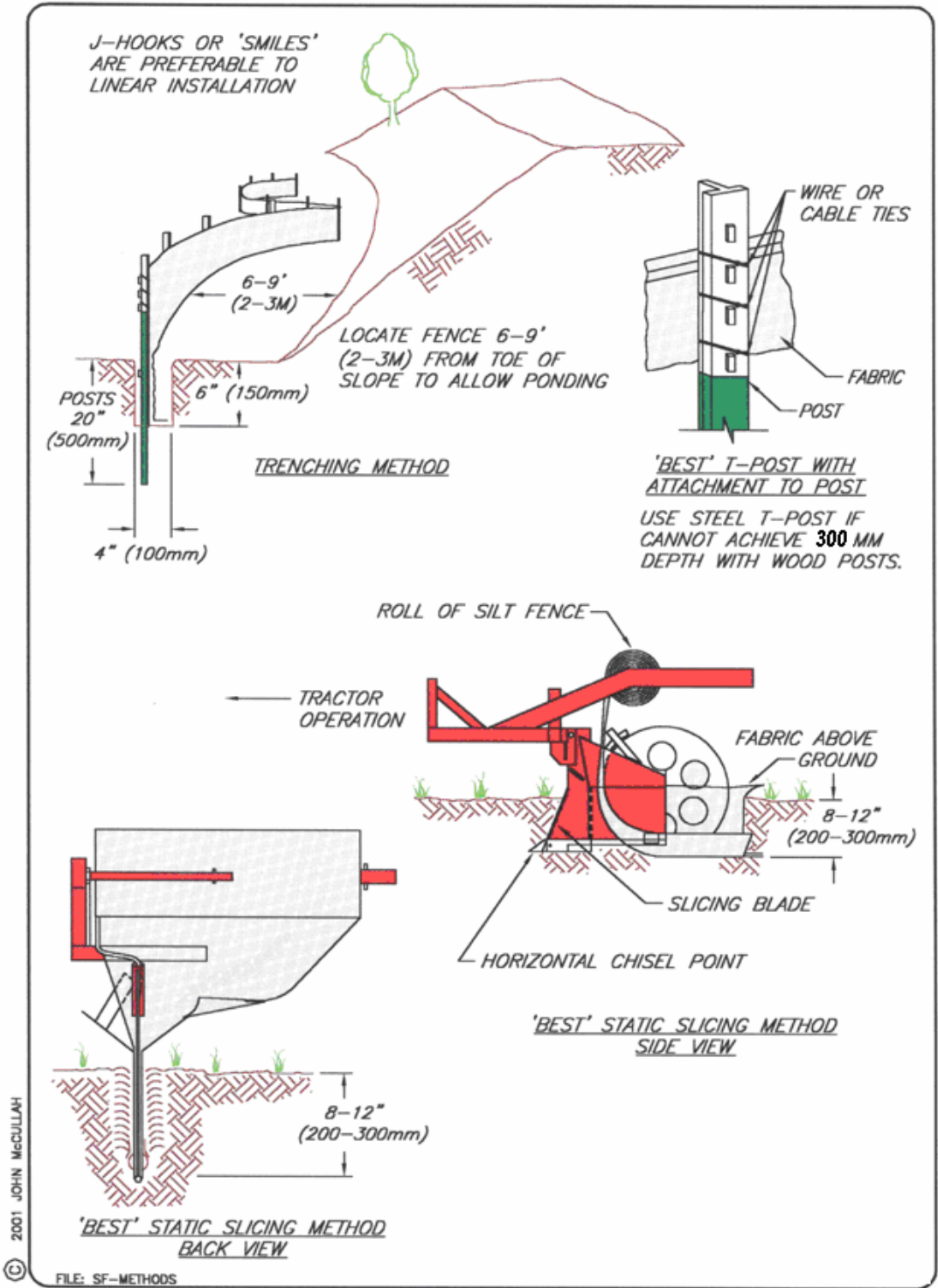

Figure 1.4-D Silt Fence Installation

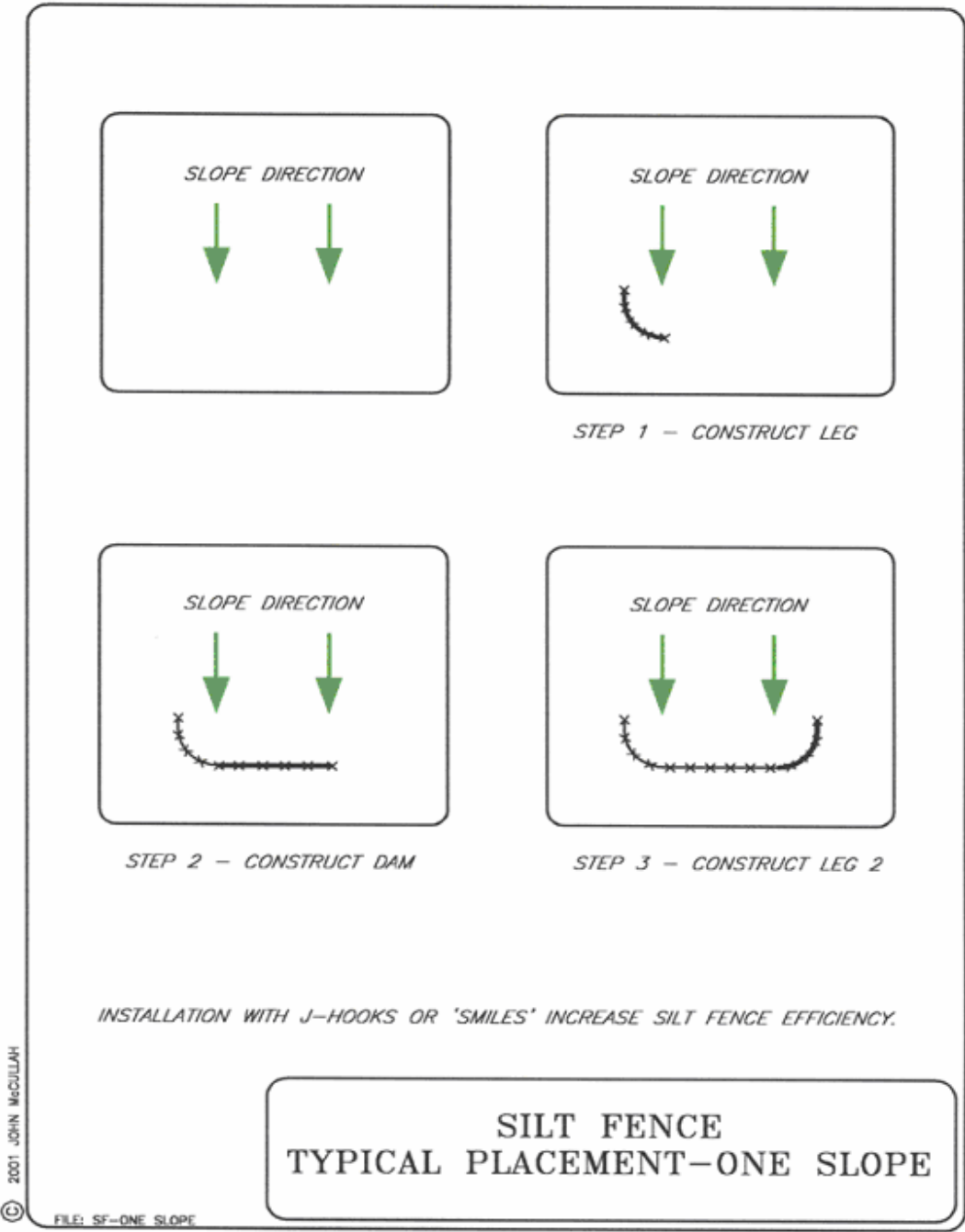
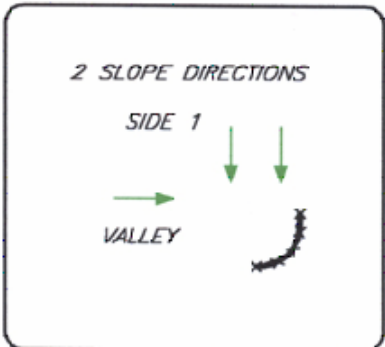
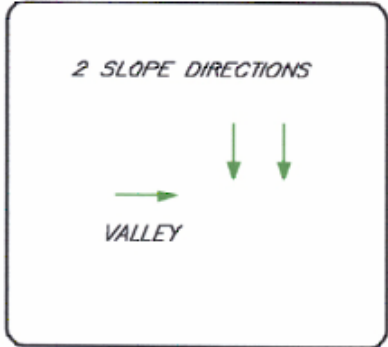
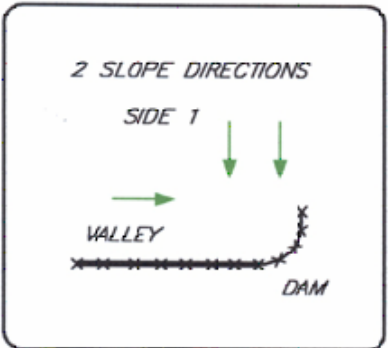

Figure 1.4-E Silt Fence Typical Placement – One Slope



STEP 1 - CONSTRUCT A DAM



STEP 2 - CONSTRUCT SIDE 2

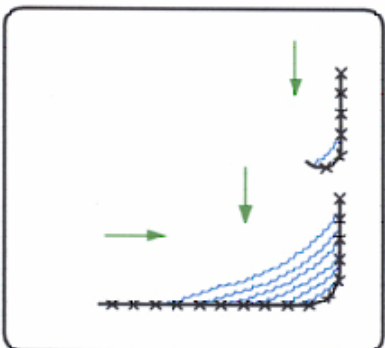

STEP 3 - CONSTRUCT J-HOOKS AS NEEDED

INSTALLATION WITH J-HOOKS WILL INCREASE SILT FENCE EFFICIENCY AND REDUCE EROSION-CAUSING FAILURES.

**SILT FENCE  
TYPICAL PLACEMENT-TWO SLOPES**

Figure 1.4-F Silt Fence Typical Placement – Two Slopes

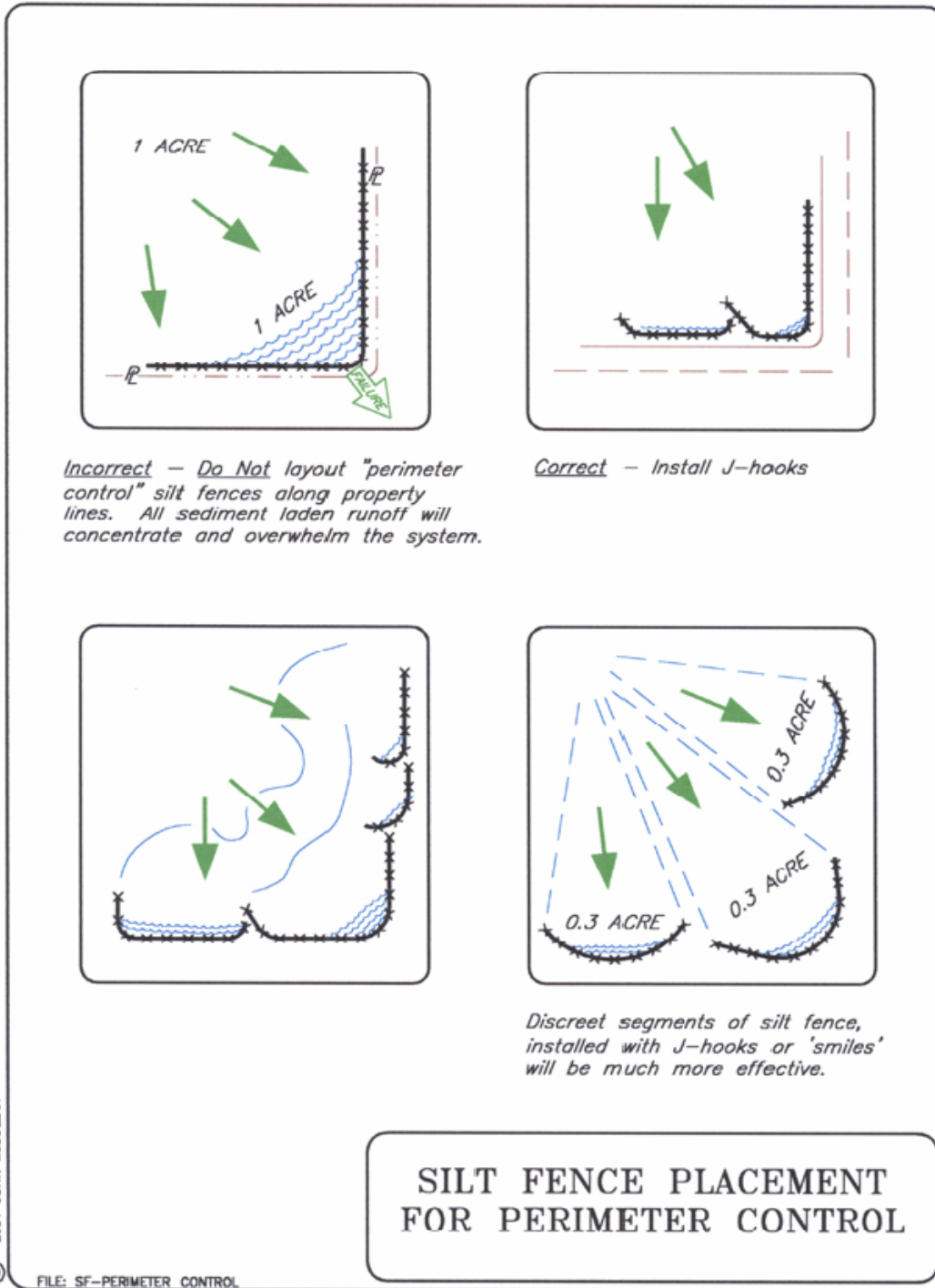
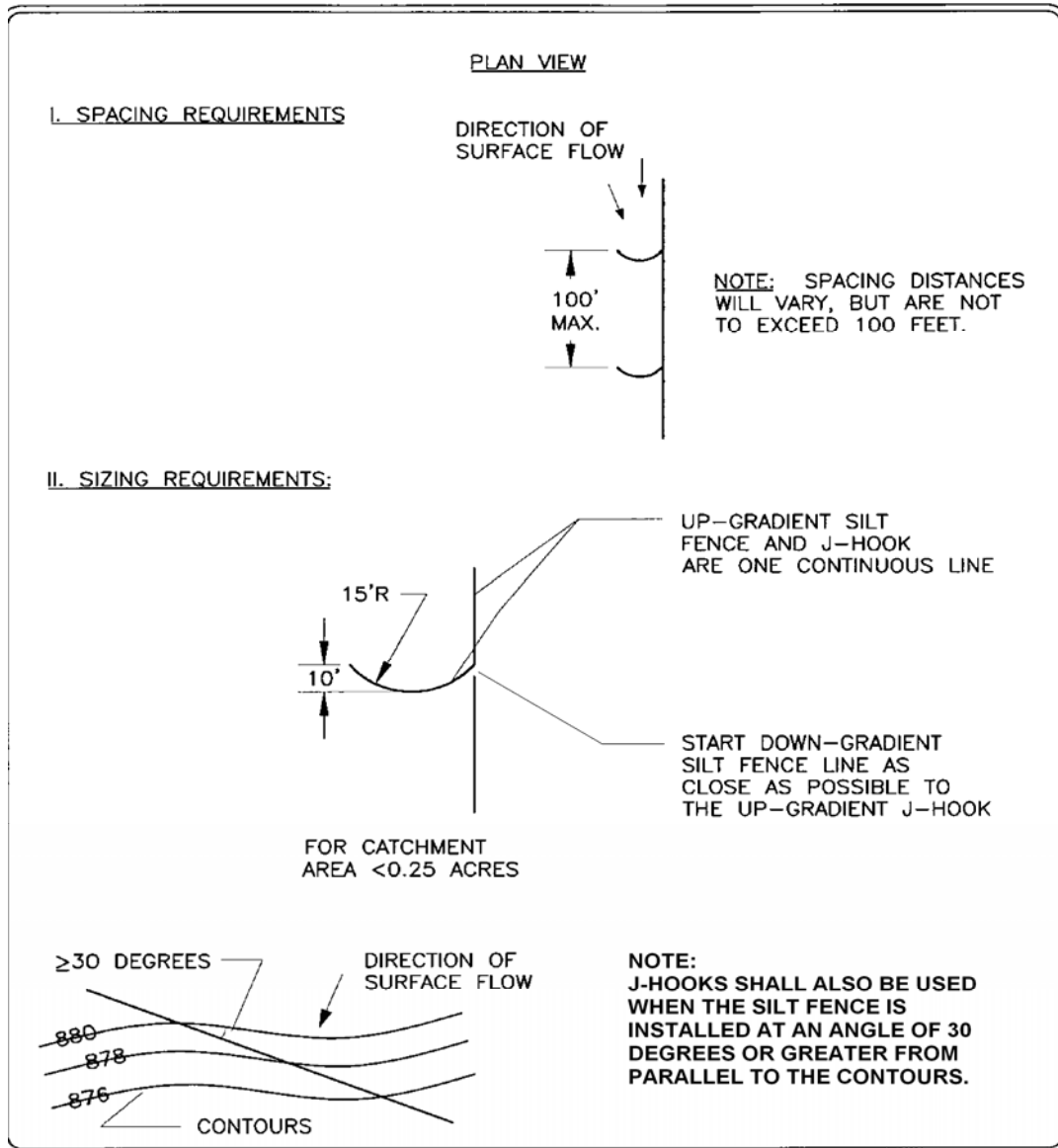

Figure 1.4-G Silt Fence Placement for Perimeter Control



**Figure 1.4-H Silt Fence J - Hook Detail (N.T.S.)**

**H. Triangular Sediment Filter Dikes.**

(See Standard Specifications manual item 648S and Specifications manual item 648S for detail)

**1. Description.**

A temporary barrier constructed of wire mesh and geotextile fabric, installed along a flat area.

**2. Purpose.**

The purpose of a triangular sediment filter dike is to intercept and detain water-borne sediment from a stabilized construction entrance, roadway

utility work, small utility repairs, underground storage tank removals, or minor redevelopment projects.

### **3. Conditions Where Practice Applies.**

The triangle sediment filter dike is used where:

- There is no concentration of water in a channel or other drainage way above the barrier, and
- If concentrated flow occurs after installation, corrective action must be taken such as placing rock berms in the areas of concentrated flow.
- Contributing drainage area is limited to sheet flow from the stabilized construction entrance. Additionally, the triangle sediment filter dike should be placed across the construction entrance(s) at the end of the day to form a continuous perimeter sedimentation control in conjunction with other approved perimeter controls.
- There is work within a parking lot covered with asphalt, the dike should be placed on the asphalt and the skirt weighed down with rock or a continuous wood strip nailed to the asphalt.
- There is roadway or small utility work. The dike should be placed to intercept stormwater prior to entering the inlet.
- There is underground storage tank removal or installation.
- There is minor redevelopment on a site and no other types of sediment control are feasible.

### **4. Design Criteria.**

(See City of Austin Standard Specification 628S.)

#### ***I. Hay Bale Dikes.***

(See Standard Specifications manual item 628S and Specifications manual item 628S-1 for detail)

##### **1. Description.**

A temporary barrier constructed with hay bales with a life expectancy of two (2) months or less.

##### **2. Purpose.**

The purpose of a hay bale dike is to intercept and detain small amounts of sediment from unprotected areas of limited extent. The use of this type of sediment control is only acceptable for above ground and under ground storage tank construction or removal projects.

##### **3. Conditions Where Practice Applies.**

The hay bale dike is used where:

- No other practice is feasible, and
- There is no concentration of water in a channel or other drainage way above the barrier and

- If concentrated flow occurs after installation, corrective action must be taken such as placing rock berms in the areas of concentrated flow.
- Construction activities and revegetation will be completed in three (3) months or less.
- Contributing drainage area is less than 2,500 square feet.

#### **4. Design Criteria.**

A design is not required. The following criteria shall be observed:

All bale dikes shall be placed on the contour. Bales shall be embedded a minimum of four (4) inches and securely anchored using 3/8 inch diameter rebar stakes driven through the bales. Bales that are not able to be imbedded and are place on impervious cover should be placed level with the concrete and have all bales butted end to end with no voids or gaps between them. Bales shall be bound by either wire or nylon string. Jute or cotton binding is unacceptable. Bales shall be replaced every two (2) months or more often during wet weather when loss of structural integrity is accelerated.

### **J. Mulch Berm**

#### **1. Description.**

Mulch Berm is a temporary sedimentation control made of wood mulch, wood chips, or other organic material used to intercept sheet flow and pond runoff. Mulch berms provide a three-dimensional filter that retains sediment and other pollutants (e.g., suspended solids) while allowing the cleaned water to flow through the berm. Mulch berms can be used in place of traditional sediment controls such as a silt fence or in conjunction with other approved controls.

The effectiveness of using Mulch berm as a sediment control technique depends on:

- The type of mulch used
- Mulch morphology
- Drainage area to section of berm
- Method of application: the mulch berm material can be placed mechanically or by hand.
- Soil type
- Slope
- Climatic characteristics
- Proper preparation of application area (uniform application surface to ensure optimal mulch to soil contact)

#### **2. Materials.**

Mulch berm material can be manufactured on or off the project site. It consists primarily of organic material, separated at the point of generation, and may include: shredded bark, stump grindings, or composted bark

The mulch berm shall have the following composition:

- Use untreated wood chips less than or equal to 5 inches in length with 95% passing a 2-inch screen and less than 30% passing a 1-inch screen (TXDOT Special Specification 1011, Mulch Filter Berm).
- Large portions of silts, clays, or fine sands are not acceptable in the mix.

Mulch berm material is composed of a mixture of particle sizes and may contain rocks less than 2 inches in diameter. Mulch berm material must be free of refuse, physical contaminants, and material toxic to plant growth. It is not acceptable for the mulch berm material to contain ground construction debris, biosolids, or manure.

Prior to placement a representative sample of the mulch berm material must be tested and certified by the project engineer or his/her designee and accepted by the city inspector.

### **3. Installation.**

A Mulch Berm is not allowed on 2:1 slopes or steeper.

Mulch Berm maximum slope spacing criteria must be followed (see Table 1.4-A)

Mulch Berms should be a minimum 24 inches high and 36 inches wide. (Figure 1.4-I).

Mulch Berms should be installed parallel to the base of the slope or the other affected area. For best filtration, a mulch berm should be placed on the level contour of a slope so that flows are dissipated into uniform sheet flow which has little energy for transporting sediment (see Silt Fence.).

The mulch may be placed with a hydraulic bucket, a pneumatic blower, or by hand.

When a diversion or perimeter control mulch berm is installed in the direction of a slope, a 20-foot length of berm should be turned in, across the slope, at regular intervals (See Table 1.4-A) to create a "J"-hook (see Figure 1.4-H). These "J"-hooks act as check dams, controlling the velocity of the diverted runoff as it travels along the berm.

### **4. Where a mulch berm is not allowed as a sediment control.**

- On slopes with groundwater seepage;
- In concentrated flow situations or in runoff channels;
- On slopes equal to or steeper than 2:1;
- At the bottom of steep perimeter slopes exceeding 100 feet in length (large up-gradient watershed);
- Below culvert outlet aprons, and
- Around catch basins and closed storm system outlets.
- Within a stormwater control structure.

**5. Inspection and Maintenance.**

Inspect every 7-days and within 24-hours of a rainfall event of 0.5 inches or greater event and replace or repair if necessary.

Sediments collected at the base shall be removed when they reach 1/3 of the exposed height of the mulch berm.

Vegetation adds stability and should be promoted.

If the mulch is not removed prior to revegetation, it should be spread out into the landscape to a depth that will not prevent seed germination and encourage effective revegetation of the site.

**References:**

City of Austin, Mabel Davis Park Site Remediation, Standard Technical Specifications, Compost/Mulch Filter Berm - Section 02273 (2004), Volume 2

Storey, et al. (2006), Water Quality Characteristics and Performance of Compost Filter Berms, Report 0-4572-1, Texas Department of Transportation

Demars, and Long (2001), Performance Specifications for Wood Waste Materials as an Erosion Control Mulch and as a Filter Berm, NETCR 25.

**Table 1.4-C Mulch Berm Slopes and Maximum Slope Lengths**

Slope	Max. Slope Length Between Berms (feet)
100:1-50:1	100
50:1-10:1	75
10:1-5:1	50
5:1-2:1	10

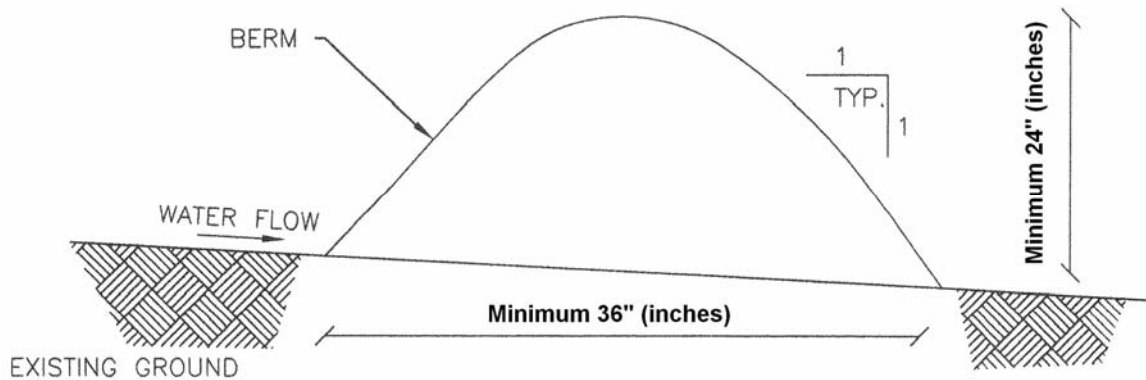

**Figure 1.4-I Mulch Berm**

## **K. Sediment Basin**

### **1. Definition.**

An earthen embankment suitably located to capture runoff, with a trapezoidal spillway lined with an impermeable geotextile or laminated plastic membrane, and equipped with a floating skimmer for dewatering.

### **2. Purpose.**

Sediment basins are designed to provide an area for runoff to pool and settle out a portion of the sediment carried down gradient. Past designs used a perforated riser for dewatering, which allowed water to leave the basin from all depths. One way to improve the sediment capture rate is to have an outlet which dewater the basin from the top of the water column where the water is cleanest. A skimmer is probably the most common method to dewater a sediment basin from the surface. The basic concept is that the skimmer does not dewater the basin as fast as runoff enters it, but instead allows the basin to fill and then slowly drain over hours or days. This process has two effects. First, the sediment in the runoff has more time to settle out prior to discharge. Second, a pool of water forms early in a storm event and this further increases sedimentation rates in the basin. Many of the storms will produce more volume than the typical sediment basin capacity and flow rates in excess of the skimmer capability, resulting in flow over the emergency spillway. This water is also coming from the top of the water column and has thereby been “treated” to remove sediment as much as possible. (Adapted from Soil Facts: Dewatering Sediment Basins Using Surface Outlets. N. C. State University, Soil Science Department.)

### **3. Conditions Where Practice Applies.**

Skimmer sediment basins are needed where drainage areas are too large for temporary sediment traps. Do not locate the skimmer sediment basin in intermittent or perennial streams.

### **4. Planning Considerations.**

Select locations for skimmer basins during initial site evaluation. Install skimmer sediment basins before any site grading takes place within the drainage area.

Select skimmer sediment basin sites to capture sediment from all areas that are not treated adequately by other sediment control measures. Always consider access for cleanout and disposal of the trapped sediment. Locations where a pond can be formed by constructing a low dam across a natural swale are generally preferred to sites that require excavation. Where practical, divert sediment-free runoff away from the basin.

A skimmer is a sedimentation basin dewatering control device that withdraws water from the basin’s water surface, thus removing the highest quality water for delivery to the uncontrolled environment. A skimmer is shown in Figure 1.4-J. By properly sizing the skimmer’s control orifice, the skimmer can be made to dewater a design hydrologic event in a prescribed period. Because the spillway is actually used relatively frequently, it should be carefully stabilized using geotextiles, or rock if necessary, that can withstand the expected flows. The spillway should be placed as far from

the inlet of the basin as possible to maximize sedimentation before discharge. The spillway should be located in natural groundcover to the greatest extent possible

The costs of using a skimmer system are similar, or occasionally less, than a conventional rock outlet or perforated riser. However, the basin is more efficient in removing sediment. Another advantage of the skimmer is that it can be reused on future projects. The main disadvantage of the skimmer is that it does require frequent maintenance, primarily in removing debris from the inlet.

A skimmer must dewater the basin from the top of the water surface. The rate of dewatering must be controlled. A dewatering time of 24 to 72 hours is required. Any skimmer design that dewateres from the surface at a controlled rate is acceptable.

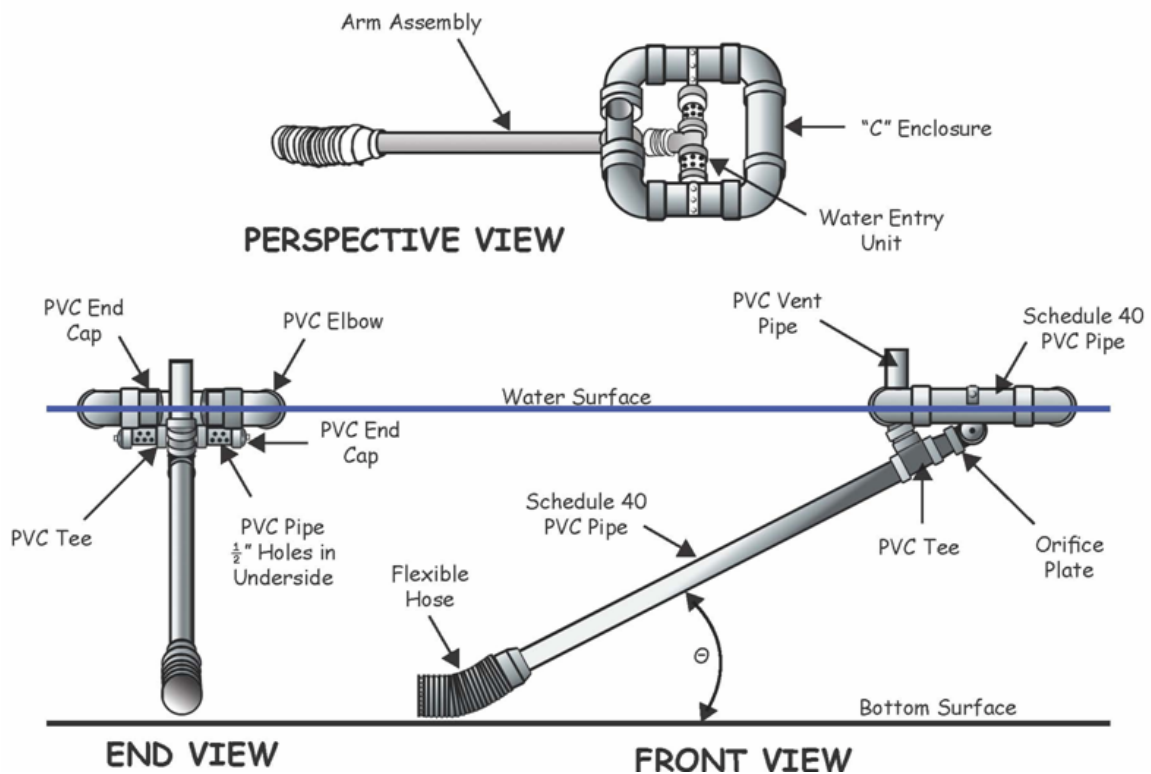

**Figure 1.4-J Schematic of a Skimmer (from Pennsylvania Erosion and Sediment Pollution Control Manual, March 2000)**

### 5. Skimmer Orifice Diameter.

In order to streamline the orifice sizing procedure, Figure 1.4-K, may be used. This design chart assumes the designer knows or has determined the sedimentation basin's water storage volume in cubic feet and the desired dewatering time (in days) for the basin under consideration. The skimmer orifice size (in inches) can be read by entering Figure 1.4-K from

the x-axis with the basin's water storage volume (in cubic feet), moving vertically to the line that represents the basin's desired dewatering time (in days), then moving to the left to the y-axis.

### 6. Design Example.

The design professional in charge of designing the sedimentation basin for a 10-acre construction site desires to use a skimmer to control dewatering of a sedimentation basin. The sedimentation basin for a 10-acre disturbed area requires a water storage volume of 18,000 cubic feet. The desired dewatering time is 1-3 days.

**Solution.** Using the water storage volume of 18,000 cubic feet and the 1-3 day dewatering time on , Figure 1.4-K, a 2-inch orifice diameter is required. (Adapted from Proper Sizing of the Control Orifice for the Faircloth Skimmer. Pennsylvania State University Department of Agricultural and Biological Engineering Fact Sheet #252.)

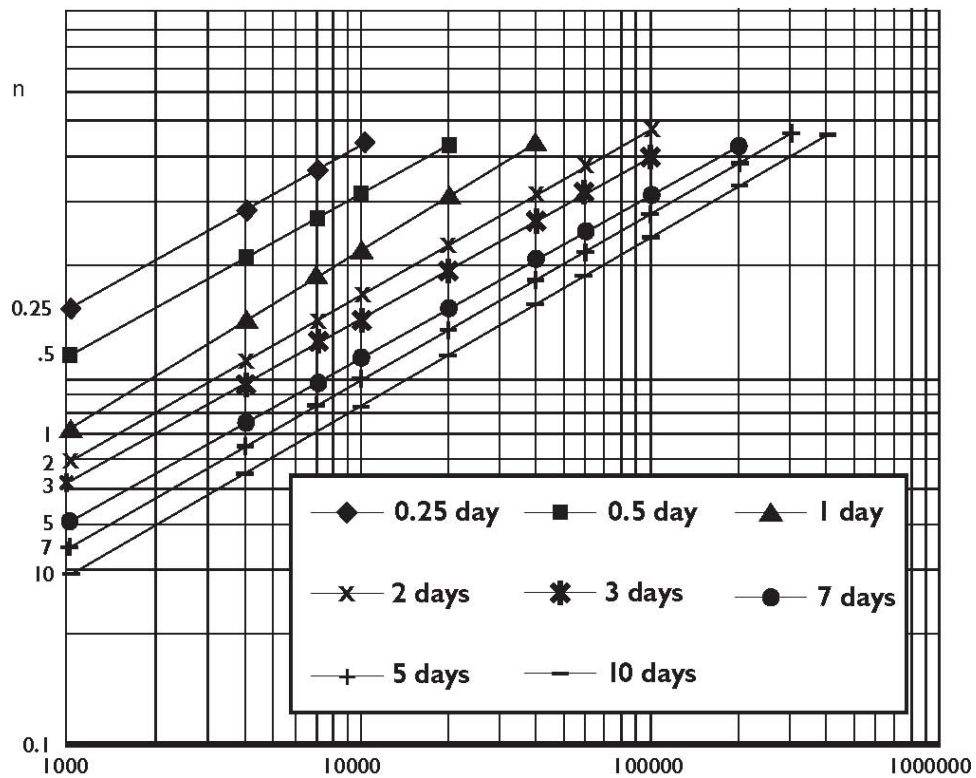

Figure 1.4-K Skimmer orifice diameter as a function of the basin volume and basin dewatering time. Rev. 6/06 6.64.3

Table 1.4-D Skimmer Design Criteria

Summary	Skimmer Sediment Basin
Primary Spillway	Trapezoidal spillway with impermeable membrane
Maximum drainage area	10 acres

Summary	Skimmer Sediment Basin
Minimum volume	1800 Cubic Feet per acre of disturbed area
Minimum surface area	325 square feet per cfs of Q <sub>10</sub> peak flow
Minimum L/W ratio	2:1
Maximum L/W ratio	6:1
Maximum depth	2 feet
Dewatering mechanism	Skimmer
Minimum Dewatering time	24 Hours
Baffles required	3 baffles

## 7. Design Considerations.

**Drainage areas** – Limit drainage areas to 10 acres.

**Design basin life** – Ensure a design basin life of 3 years or less.

**Dam height** – Limit dam height to 5 feet.

**Basin locations**—Select areas that:

- Provide capacity for storage of sediment from as much of the planned disturbed area as practical;
- Exclude runoff from undisturbed areas where practical;
- Provide access for sediment removal throughout the life of the project;
- Interfere minimally with construction activities.

**Basin shape** – Ensure that the flow length to basin width ratio is at least 2:1 to improve trapping efficiency. Length is measured at the elevation of the principal spillway.

**Storage volume** – Ensure that the sediment storage volume of the basin, as measured to the elevation of the crest of the principal spillway, is at least 1,800 cubic feet per acre for the disturbed area draining into the basin (1,800 cubic feet is equivalent to half an inch of sediment per acre of basin disturbed area).

Remove sediment from the basin when approximately one-half of the storage volume has been filled.

**Spillway capacity** – The spillway system must carry the peak runoff from the 10-year storm with a minimum 1 foot of freeboard in the spillway. Base runoff computations on the disturbed soil cover conditions expected during the effective life of the structure.

**Sediment cleanout elevation** – the elevation at which the invert of the basin would be half-full. This elevation should also be marked in the field with a permanent stake set at this ground elevation (not the top of the stake).

**Basin dewatering** – The basin should be provided with a surface outlet. A floating skimmer should be attached to a Schedule 40 PVC barrel pipe of the same diameter as the skimmer arm. The orifice in the skimmer will control the rate of dewatering. The skimmer should be sized to dewater the basin in 24-72 hours (1-3 days).

**Outlet Protection** – Discharge velocities must be within allowable limits for the receiving stream (References: Outlet Protection).

**Basin spillway** – Construct the entire flow area of the spillway in undisturbed soil if possible. Make the cross section trapezoidal with side slopes of 3:1 or flatter.

- **Capacity** – The minimum design capacity of the spillway must be the peak rate of runoff from the 10-year storm. Maximum depth of flow during the peak runoff should be 6 inches. In no case should the freeboard of the spillway be less than 1 foot above the design depth of flow.
- **Velocity** – Ensure that the velocity of flow discharged from the basin is non-erosive for the existing conditions. When velocities exceed that allowable for the receiving areas, provide outlet protection (References: Outlet Protection).

**Embankment** – Ensure that embankments for skimmer sediment basins do not exceed 5 feet in height (measured at the center line from the original ground surface to the top of the embankment). Keep the crest of the spillway outlet a minimum of 1.5 feet below the top of the embankment. Additional freeboard may be added to the embankment height which allows flow through a designated bypass location. Construct embankments with a minimum top width of 5 feet and side slopes of 2:1 or flatter. Machine compact the embankments.

**Excavation** – Where sediment pools are formed or enlarged by excavation, keep side slopes at 2:1 or flatter for safety.

**Erosion protection** – Stabilize all areas disturbed by construction (except the lower half of the sediment pool) by suitable means immediately after completing the basin (References: Surface Stabilization).

**Trap efficiency** – Improve sediment basin trapping efficiency by employing the following considerations in the basin design:

- **Surface area** – In the design of the settling pond, allow the largest surface area possible.
- **Length** – Maximize the length-to-width ratio of the basin to prevent short circuiting, and ensure use of the entire design settling area.
- **Baffles** – Provide a minimum of three porous baffles to evenly distribute flow across the basin and reduce turbulence.
- **Inlets** – Area between the sediment inlets and the basin should be stabilized by geotextile material, with or without rocks (Figure 1.4-L shows the area with rocks). The inlet to basin should be located the greatest distance possible from the principal spillway.

- **Dewatering** – Allow the maximum reasonable detention period before the basin is completely dewatered (at least 24 hours).
- **Inflow rate** – Reduce the inflow velocity and divert all sediment-free runoff.

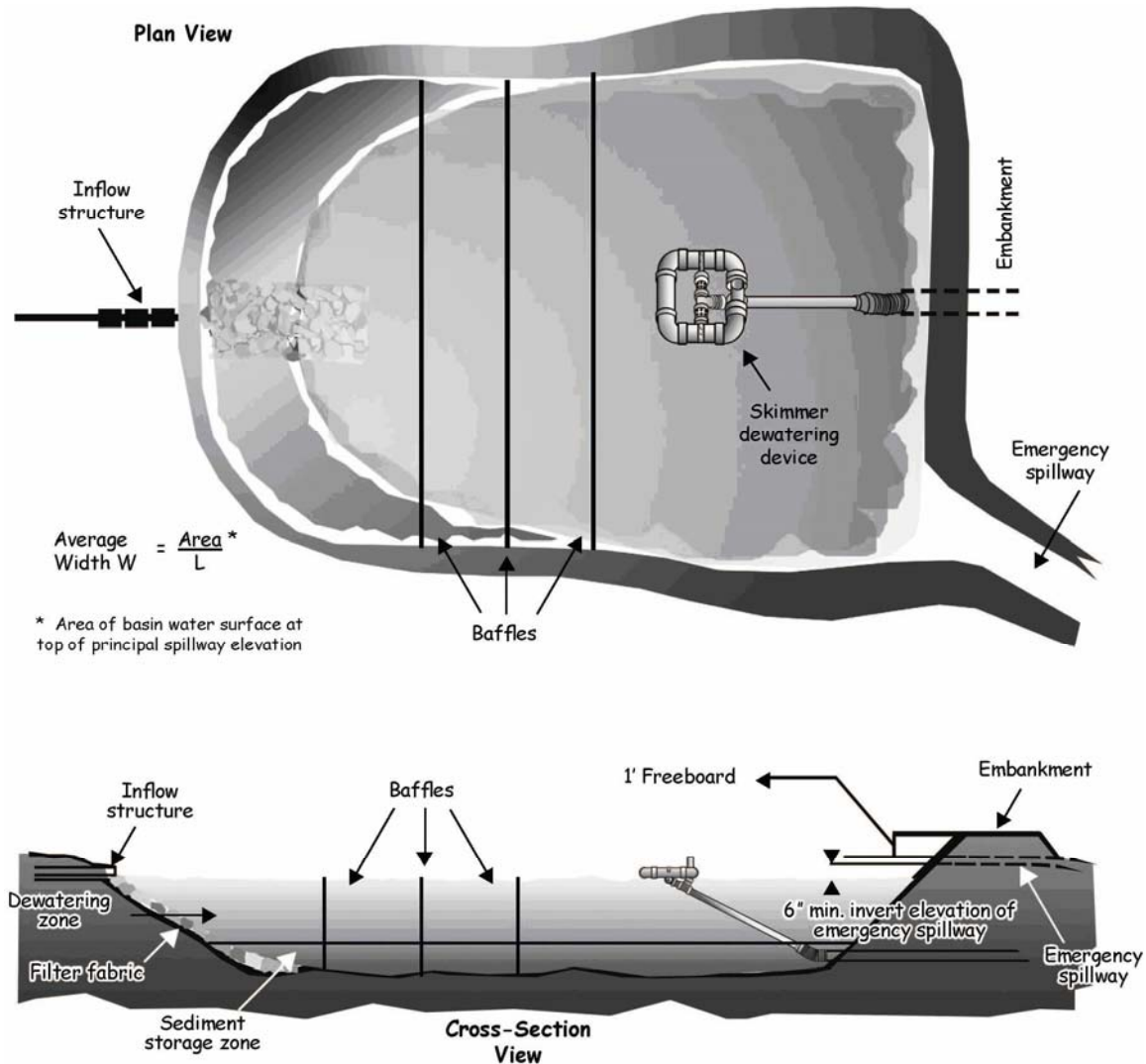

**Figure 1.4-L Example of a Sediment Basin with a Skimmer Outlet and Emergency Spillway (from Pennsylvania Erosion and Sediment Pollution Control Manual, March 2000)**

### 8. Construction Specifications.

1. Clear, grub, and strip the area under the embankment of all vegetation and root mat. Remove all surface soil containing high amounts of organic matter and stockpile or dispose of it properly. Haul all objectionable

material to the designated disposal area. Place temporary sediment control measures below basin as needed

2. Ensure that fill material for the embankment is free of roots, woody vegetation, organic matter, and other objectionable material. Place the fill in lifts not to exceed 9 inches, and machine compact it. Over fill the embankment 6 inches to allow for settlement.

3. Shape the basin to the specified dimensions. Prevent the skimming device from settling into the mud by excavating a shallow pit under the skimmer or providing a low support under the skimmer of stone or timber.

4. Place the barrel (typically 4-inch Schedule 40 PVC pipe) on a firm, smooth foundation of impervious soil. Do not use pervious material such as sand, gravel, or crushed stone as backfill around the pipe. Place the fill material around the pipe spillway in 4-inch layers and compact it under and around the pipe to at least the same density as the adjacent embankment. Care must be taken not to raise the pipe from the firm contact with its foundation when compacting under the pipe haunches.

Place a minimum depth of 2 feet of compacted backfill over the pipe spillway before crossing it with construction equipment. In no case should the pipe conduit be installed by cutting a trench through the dam after the embankment is complete.

5. Assemble the skimmer following the manufacturers instructions, or as designed.

6. Lay the assembled skimmer on the bottom of the basin with the flexible joint at the inlet of the barrel pipe. Attach the flexible joint to the barrel pipe and position the skimmer over the excavated pit or support. Be sure to attach a rope to the skimmer and anchor it to the side of the basin. This will be used to pull the skimmer to the side for maintenance.

7. Earthen spillways – Install the spillway in undisturbed soil to the greatest extent possible. The achievement of planned elevations, grade, design width, and entrance and exit channel slopes are critical to the successful operation of the spillway. The spillway should be lined with laminated plastic or impermeable geotextile fabric. The fabric must be wide and long enough to cover the bottom and sides and extend onto the top of the dam for anchoring in a trench. The edges may be secured with 8-inch staples or pins. The fabric must be long enough to extend down the slope and exit onto stable ground. The width of the fabric must be one piece, not joined or spliced; otherwise water can get under the fabric. If the length of the fabric is insufficient for the entire length of the spillway, multiple sections, spanning the complete width, may be used. The upper section(s) should overlap the lower section(s) so that water cannot flow under the fabric. Secure the upper edge and sides of the fabric in a trench with staples or pins. (Adapted from “A Manual for Designing, Installing and Maintaining Skimmer Sediment Basins.” February, 1999. J. W. Faircloth & Son.).

8. Inlets – Discharge water into the basin in a manner to prevent erosion. Use temporary slope drains or diversions with outlet protection to divert sediment-laden water to the upper end of the pool area to improve basin

trap efficiency (References: Runoff Control Measures and Outlet Protection).

Rev. 6/06 6.64.7

9. Erosion control—Construct the structure so that the disturbed area is minimized. Divert surface water away from bare areas. Complete the embankment before the area is cleared. Stabilize the emergency spillway embankment and all other disturbed areas above the crest of the principal spillway immediately after construction (References: Surface Stabilization).

10. Install porous baffles as specified in Practice 6.65, Porous Baffles.

11. After all the sediment-producing areas have been permanently stabilized, remove the structure and all the unstable sediment. Smooth the area to blend with the adjoining areas and stabilize properly (References: Surface Stabilization).

Rev. 6/06 6.64.7

### **References.**

Jarrett, A. R. Proper Sizing of the Control Orifice for the Faircloth Skimmer. Pennsylvania State University Department of Agricultural and Biological Engineering Fact Sheet #252.

<http://www.age.psu.edu/extension/factsheets/f/F252.pdf>

Jarrett, A. R. Controlling the Dewatering of Sedimentation Basins. Pennsylvania State University Department of Agricultural and Biological Engineering Fact Sheet #253.

<http://www.age.psu.edu/extension/factsheets/f/F253.pdf>

Erosion and Sediment Pollution Control Manual, March, 2000. Commonwealth of Pennsylvania Dept. of Environmental Protection, Office of Water Management, Document #363-2134-008.

<http://www.co.centre.pa.us/conservation/esmanual.pdf>

McLaughlin, Richard. SoilFacts: Dewatering Sediment Basins Using Surface Outlets, N. C. State University, Soil Science Department.

A Manual for Designing, Installing and Maintaining Skimmer Sediment Basins. February, 1999. J. W. Faircloth & Son.

### **9. Maintenance**

Inspect skimmer sediment basins at least weekly and after each significant (one-half inch or greater) rainfall event and repair immediately. Remove sediment and restore the basin to its original dimensions when sediment accumulates to one-half the height of the first baffle. Pull the skimmer to one side so that the sediment underneath it can be excavated. Excavate the sediment from the entire basin, not just around the skimmer or the first cell. Make sure vegetation growing in the bottom of the basin does not hold down the skimmer.

Repair the baffles if they are damaged. Re-anchor the baffles if water is flowing underneath or around them.

If the skimmer is clogged with trash and there is water in the basin, usually jerking on the rope will make the skimmer bob up and down and dislodge the debris and restore flow. If this does not work, pull the skimmer over to the side of the basin and remove the debris. Also check the orifice inside the skimmer to see if it is clogged; if so remove the debris.

If the skimmer arm or barrel pipe is clogged, the orifice can be removed and the obstruction cleared with a plumber's snake or by flushing with water. Be sure and replace the orifice before repositioning the skimmer.

Check the fabric lined spillway for damage and make any required repairs with fabric that spans the full width of the spillway. Check the embankment, spillways, and outlet for erosion damage, and inspect the embankment for piping and settlement. Make all necessary repairs immediately. Remove all trash and other debris from the skimmer and pool areas.

Freezing weather can result in ice forming in the basin. Some special precautions should be taken in the winter to prevent the skimmer from plugging with ice.

6.64.8 Rev. 6/06

Sedimentation basins shall not be allowed as stand alone BMPs. Applicant must demonstrate appropriate site management practices, temporary stabilization measures, perimeter and internal controls instead of just relying on a sediment basin at the outlet of the project. Temporary sediment basins and traps are not allowed to be constructed in concentrated flow paths, draws, creeks or other drainage features exist that have contributing drainage areas greater than 40 acres.

Detention/sedimentation structures must be designed to withstand the force and velocity from a 10-year frequency storm without failing. Larger storms shall be bypassed via stabilized conveyances. Those devices that employ sedimentation must provide the storage volume for the runoff from a 2-year, 24 hour storm under compacted site conditions. The sedimentation basins must be designed such that drawdown time is 72 hours via surface skimmers. The design must include considerations for overflows to ensure that the device and its detention pool remain intact. Detention/sedimentation structures shall not be sited in natural drainage channels, draws or ravines that are directly connected to off-site drainage features like creeks, rivers, ponds or recharge features. In particular, this means that silt fences shall not be used to control concentrated or channelized flow and sedimentation basins shall not be constructed in natural draws because failures of the earthen retaining system are often catastrophic to the downstream receiving waters.

- **Anti-seep** – anti-seep collars will be required when the soil conditions or length of service make piping through the backfill a possibility.
- The number of collars shall be determined from the backfill conditions and the length of pipe installed.

- Cutoff collars will be spaced at not more than 25 foot centers. If only one (1) is used, it should be placed not more than 25 feet from the riser. Collars and their connections to the pipe shall be watertight and located no closer than two (2) feet to a pipe joint.
- Emergency spillway - Emergency spillways shall be constructed so as to handle the 25 year frequency storm without damage to the structure from erosion. The emergency spillway cross section shall be trapezoidal with a minimum bottom width of ten (10) feet.
  - The minimum capacity of the emergency spillway shall be that required to pass the peak rate of runoff from the 25 year frequency storm, less any reduction due to flow in the riser.
  - Velocities - The velocity of flow in the exit channel shall not exceed maximum permissible velocities for vegetated channels. For channels with erosion protection other than vegetation, velocities shall be within the non-erosive range for the type of protection used.
  - Erosion protection - Erosion protection shall be provided by vegetation as prescribed in this manual.
  - Freeboard - Freeboard is the difference between the design high water elevation in the emergency spillway and the top of the compacted embankment. If there is no emergency spillway, it is the difference between the water surface elevation required to pass the design flow through the discharge piping and the top of the compacted embankment. The freeboard shall be at least one (1) foot.

#### **10. Embankment Cross Section.**

The minimum top width shall be three (3) feet. The side slopes shall not be steeper than 3:1.

#### **11. Entrance of Runoff into Basin.**

Points of entrance of surface runoff into excavated sediment basins shall be protected to prevent erosion. Diversions, grade stabilization structures or other water control devices shall be installed as necessary to insure direction of runoff and protect points of entry into the basin.

#### **12. Disposal.**

The sediment shall be placed in an approved spoils disposal site.

#### **13. Safety.**

Sediment basins are attractive to children and can be very dangerous. Therefore, they shall be fenced or otherwise made inaccessible to people or animals, unless this is deemed unnecessary due to the remoteness of the site or other circumstances.

#### **14. Information to be Submitted with Design.**

Sediment basin design and construction plans submitted for review to the City of Austin shall include all relevant information as required by the

Administrative Criteria Manual. The following outlines this relevant information:

- Specific location of basin.
- Plan view of dam, storage basin and emergency spillway.
- Cross section of dams, low-flow riser and emergency spillway; profile of emergency spillway.
- Details of pipe connections, riser to pipe connection, riser base, trash rack, anti-vortex device and when required, anti-seep collars.
- Runoff calculations for the two (2) year and 25 year frequency storms.
- Storage Computation:
  - Total required.
  - Total available.
  - Level of sediment at which cleanout shall be required; to be stated as a distance from the riser crest to the sediment surface.
  - Calculations showing design of piping and emergency spillway.
  - Other information deemed necessary by the Watershed Protection and Development Review Department.

#### ***L. Sediment Trap.***

*(See Standard Specifications manual item 644S and Specifications manual item 644S-1 for detail.)*

##### **1. Description.**

A small temporary basin formed by excavation and/or an embankment to intercept sediment-laden runoff and to trap and retain the sediment.

##### **2. Purpose.**

The purpose of a sediment trap is to intercept sediment-laden runoff and trap the sediment in order to protect drainageways, properties and rights of way below the sediment trap from sedimentation.

##### **3. Conditions Where Practice Applies.**

A sediment trap is usually installed at points of discharge from disturbed areas.

##### **4. Design Criteria.**

If any of the design criteria presented here cannot be met, see Section 1.4.5 K "Sediment Basin".

##### **5. Drainage Area.**

The drainage area for a sediment trap is recommended to be less than five (5) acres.

## **6. Location.**

The sediment trap should be located to obtain the maximum storage benefit from the terrain, for ease of cleanout and disposal of the trapped sediment and to minimize interference with construction activities.

## **7. Trap Size.**

The volume of a sediment trap as measured at the elevation of the crest of the outlet shall be at least 1800 cubic feet per acre of drainage area. The volume of the trap shall be calculated using standard mathematical procedures.

## **8. Trap Cleanout.**

Sediment shall be removed and the trap restored to its original dimensions when the sediment has accumulated to  $\frac{1}{2}$  of the design depth of the trap or one (1) foot, whichever is less. Sediment removed from the trap shall be deposited in an approved spoils area and in such a manner that it will not cause additional siltation.

## **9. Embankment.**

The embankment shall be mechanically compacted.

## **10. Excavation.**

All excavation operations shall be carried out in such a manner that erosion and water pollution shall be minimal. Any excavated portion of sediment trap shall have 2:1 or flatter slopes.

## **11. Outlet.**

There are two (2) types of outlets for sediment traps. Sediment traps are named according to the type of outlet. Each type has different design criteria and will be discussed separately. The outlets shall be designed, constructed and maintained in such a manner that sediment does not leave the trap and that erosion of the outlet does not occur. A trap may have several different outlets with each outlet conveying part of the flow based on the criteria below and the combined outlet capacity shall meet that criteria.

A pipe outlet sediment trap consists of a basin formed by an embankment or excavation along with an embankment. The outlet for the trap is through a perforated riser and a pipe through the embankment. The outlet pipe and riser shall be made of corrugated metal or polyvinyl chloride. The riser diameter shall be of the same or larger diameter than the pipe. The top of the embankment shall be at least 1- $\frac{1}{2}$  feet above the crest of the riser. The length of the riser shall be perforated to achieve a 40 hour or longer draw-down time. All pipe connections shall be watertight. The capacity of the riser shall be sufficient to handle the peak flow from the 25 year storm.

A stone outlet sediment trap consists of a basin formed by an embankment or excavation and an embankment. The outlet for the trap is over a level stone section. The stone outlet for a sediment trap differs from that for a stone outlet structure because of the intentional ponding of water behind the stone. To provide for a ponding area, a triple layer geotextile fabric

wrapped stone core having a nominal diameter of one (1) foot shall be placed in the outlet structure. The core shall be covered by a minimum of six (6) inches of stone.

The minimum length (feet) of the outlet shall be equal to six (6) times the drainage area (acres). The crest of the outlet (top of stone) shall be at least one (1) foot below the top of the embankment. Unless otherwise specified, all aggregate used shall be at least three (3) inches thick and shall not exceed ½ cubic foot in volume.

Geotextile fabric specification shall be woven polypropylene, polyethylene or polyamide geotextile, minimum unit weight 4.5 ounce per square yard, mullen burst strength greater than 250 pounds per square inch, ultraviolet stability exceeding 70 percent and equivalent opening size exceeding 40.

## **12. Sediment Plan Details.**

There is no standard symbol for a sediment trap. Each trap shall be delineated on the plans in such a manner that it will not be confused with any other features. Each trap on a plan shall have a number and the numbers shall be consecutive. The following information shall be shown for each trap in a summary table form on the same sheet that the trap is on:

- Type of trap;
- Size of outlet;
- Trap dimensions
- Embankment height and excavation depth;
- Drainage area.

## ***M. Sediment Trapping Devices for Excavation Pumpage.***

### **1. Description.**

A sediment tank or a temporary pit which is constructed to trap and filter sediment from water pumped from excavated areas.

### **2. Purpose.**

- **Sediment Tank** - traps and retains sediment from water being pumped from excavated areas.
- **Sump Pit** - collects water retained in excavated areas and removes sediment before the water is pumped from the site.

### **3. Conditions Where Practice Applies.**

- Sediment tanks are generally used for the period of deep excavation where space is limited.
- Sump pits are constructed for collecting water during construction; particularly useful during excavation for building foundations.

### **4. Design Criteria.**

**Sediment Tank.** The location of sediment tank shall be convenient for clean out and disposal of the trapped sediment and shall minimize the

interference with construction activities. The size of the tank can be estimated from the following formula:

Storage (cubic foot) = 16 x pump discharge (gallons per minute).

**Sump Pit.** A perforated standpipe shall be placed in the center of the pit to collect filtered water. A base of two (2) inch aggregate shall be placed in the pit to a depth of 12 inches. The pit surrounding the standpipe shall be backfilled with two (2) inch aggregate after installing the standpipe. Discharge of water pumped from the standpipe shall be conveyed to a sediment trapping device such as a rock berm, brush berm, stone outlet structure, sediment trap or sediment basin or to an area protected by any of these devices. The number of sump pits and their locations shall be determined by an engineer.

#### ***N. Stabilized Construction Entrance.***

*(See Standard Specifications manual item 641S and Specifications manual item 641S-1 for detail)*

##### **1. Description.**

A stabilized pad of crushed stone located at any point where traffic will be entering or leaving a construction site to or from a public right of way, street, alley, sidewalk or parking area.

##### **2. Purpose.**

The purpose of a stabilized construction entrance is to reduce or eliminate the tracking or flowing of sediment onto public rights of way.

##### **3. Conditions Where Practice Applies.**

A stabilized construction entrance applies to all points of construction ingress and egress.

##### **4. Design Criteria.**

The following design criteria shall be observed:

- Stone Size - Stone size shall be four (4) to eight (8) inch or larger open graded rock.
- Drainage - Entrance must be properly graded or incorporate a drainage swale to prevent runoff from leaving the construction site.
- Thickness - Not less than eight (8) inches.
- Width - Not less than full width of all points of ingress or egress.
- Length - As required, but not less than 50 feet.

##### **5. Maintenance.**

The entrance shall be maintained in a condition which will prevent tracking or flowing of sediment onto public rights of way. This may require periodic top dressing with additional stone as conditions demand and repair and/or clean out of any measures used to trap sediment. All sediment spilled,

dropped, washed or tracked onto public rights of way must be removed immediately by contractor.

When necessary, wheels must be cleaned to remove sediment prior to entrance onto public right of way. When washing is required, it shall be done on an area stabilized with crushed stone which drains into an approved sediment trap or sediment basin. All sediment shall be prevented from entering any storm drain, ditch or watercourse using approved methods.

**O. Pipe Slope Drain.**

(See Standard Specifications manual item 637S and Specifications manual item 637S-1 and 637S-2 for detail)

**1. Description.**

A flexible tubing and/or rigid pipe with prefabricated entrance section temporarily placed to extend from the top of a slope to the bottom of a slope.

**2. Purpose.**

The purpose of the pipe slope drain is to convey surface runoff safely down slopes without causing erosion.

**3. Conditions Where Practice Applies.**

Pipe slope drains are to be used where concentrated flow of surface runoff must be conveyed down a slope in order to prevent erosion. Recommended maximum drainage area is five (5) acres.

**4. Design Criteria.**

Unless otherwise specified, pipe slope drains are to be sized as follows:

**Table 1.4-E Pipe Slope Drain Sizes**

Size	Pipe/Tubing Diameter (D) (inches)	Maximum Drainage Area (acres)
PSD-12	12	.5
PSD-18	18	1.5
PSD-21	21	2.5
PSD-24	24	3.5
PSD-30	30	5.0

## **5. Inlet.**

The height of the earth dike at the entrance to the pipe slope drain shall be equal to or greater than the diameter of the pipe (D), plus 12 inches and shall be adequate to prohibit overtopping by the 100 year storm.

## **6. Outlet.**

Pipe slope drain shall outlet onto a riprap apron and then into a stabilized area or stable watercourse. A sediment trapping device shall be used to trap sediment from any sediment-laden water conveyed by the pipe slope drain.

### ***P. Inlet Protection***

(See Standard Specifications manual item 628S for detail)

#### **1. Description.**

Temporary sediment barrier made of non-woven or woven material which is water permeable but will trap water-borne sediment for protection of curb inlets with an opening to allow the passage of runoff for higher flows.

#### **2. Purpose.**

The goal of an inlet protection device is to intercept and filter water borne sediment and other pollutants from unprotected areas of limited extent and reduce the amount of sediment entering the storm system.

An inlet protection device:

- Should not cause flooding when it clogs with debris,
- Should maximize pollutant reduction,
- Should require inexpensive maintenance,
- May not be used as a stand alone method of sedimentation control.

#### **3. Conditions Where Practice Applies.**

Inlet protection is to be used for every inlet that is hydraulically connected to the limits of construction of disturbed areas. Methods where inlet protection is allowable as the primary sedimentation control shall be all construction in a street or R.O.W. including street cuts, milling operations, repair or maintenance to asphalt or subgrade, construction of turn lanes, utility installations, concrete or asphalt saw cutting, or at the direction of City of Austin personnel.

#### **4. Design Criteria.**

The inlet protection is required for both curb inlets and area inlets where disturbed areas drain to these inlets. It is not to be used as a substitute for erosion controls outside the roadway where controls could keep the sediment out of the roadway. Inlet protection should be a barrier that is set over or within the inlet that meets the goals of inlet protection mentioned above.

**Drainage Area** – less than two (2) acres.

**Material** – The fabric must correspond to requirements shown in the following table.

**Table 1.4-F Pipe Slope Drain Sizes**

<b>Property</b>	<b>Test Method</b>	<b>ASTM Requirements</b>
Fabric Weigh	D 3776	≥3.0 ounces/square yard
Ultraviolet (UV) Radiation Stability	D 4355	70% strength retained min., After 500 hours in xenon arc device
Mullen Burst Strength	D 3786	≥120 pound per square inch
Water Flow Rate	D 4491	≥275 gallons/minute/square feet

This material should have a maximum expected useful life of approximately eighteen (18) months. The inlet protection devices should be constructed in a manner that will facilitate clean out and disposal of trapped sediment while minimizing interference with construction activities. They should also be constructed such that any ponding of storm water will not cause excessive R.O.W. flooding (i.e. ≤ 4 inches of standing water) or damage to the structure or adjacent areas.

**Coverage** – The fabric/wire should completely cover the opening of the inlet and devices should be installed without protruding parts that could be a traffic, worker, or pedestrian hazard. Where sections of the fabric overlap, they shall overlap at least three (3) inches.

**Attachment** - The inlet filter shall be attached in a way that they can easily be removed and are not secured or attached by the use of sand bags. The inlet filter must be removed upon completion of work. If removal damages the concrete curb, the curb must be repaired immediately.

**5. Maintenance.**

Frequent maintenance of the inlet protection control structure is necessary to prevent clogging. Accumulated silt shall be removed when it reaches a depth of two (2) inches or one-third the height of the inlet throat, and disposed of in a manner which will not cause additional siltation.

**1.4.6 Permanent Structural Practices**

**A. Diversion.**

**1. Description.**

A drainageway of parabolic or trapezoidal cross section, with a supporting ridge on the lower side that is constructed across the slope.

## **2. Purpose.**

The purpose of a diversion is to intercept and convey runoff to stable outlets at non-erosive velocities.

## **3. Conditions Where Practice Applies.**

Diversions are used where:

- Runoff from higher areas is or has potential for damaging property, causing erosion or interfering with or preventing the establishment of vegetation on lower areas.
- The length of slopes need to be reduced so that soil loss will be reduced to a minimum.
- Diversions are only applicable below stabilized or protected areas. Avoid establishment on slopes greater than 15 percent.

## **4. Design Criteria.**

The design procedures for parabolic and trapezoidal channels shall conform to the Drainage Criteria Manual.

## **5. Location.**

Diversion location shall be determined by considering outlet conditions, topography, land use, soil type, length of slope and the layout of the proposed development.

## **6. Capacity.**

The constructed diversion shall have capacity to carry, as a minimum, the peak discharge from a ten (10) year frequency rainfall event with freeboard of not less than one (1) foot.

Diversions designed to protect homes, schools, industrial buildings, roads, parking lots and comparable high-risk areas and those designed to function in connection with other structures, shall have sufficient capacity to carry peak runoff expected from the 25 year storm.

## **7. Velocity and Grade.**

The maximum permissible velocities of flow for the native grasses and soil conditions in Travis County have not been determined. Research of this type is planned, but until it is completed, design velocities should be held to below six (6) feet per second on grades up to five (5) percent, five (5) feet per second on slopes from five (5) to ten (10) percent and four (4) feet per second on slopes over ten (10) percent.

## **8. Cross Section.**

The diversion channel shall be parabolic or trapezoidal in shape.

The diversion shall be designed to have stable side slopes. The side slopes shall not be steeper than 2:1 and shall be flat enough to insure ease of maintenance of the structure and its protective vegetative cover.

The ridge shall have a minimum width of four (4) feet at the design water elevation; a minimum of one (1) foot freeboard.

## **9. Outlets.**

Each diversion shall have a stable outlet. The outlet may be a constructed or natural waterway, a stabilized open channel, grade stabilization structure, etc. In all cases, the outlet must discharge in such a manner as not to cause erosion. Outlets shall be constructed and stabilized prior to the operation of the diversion.

### **B. Standards for Grass-Lined Swales.**

#### **1. Description.**

A natural or manmade drainageway of parabolic or trapezoidal cross section that is below adjacent ground level and is stabilized by suitable vegetation. The flow is normally wide and shallow and conveys the runoff down the slope.

#### **2. Purpose.**

The purpose of a grass-lined swale is to convey runoff without causing damage by erosion.

#### **3. Conditions Where Practice Applies.**

Grass-lined swales are used where added channel capacity and/or stabilization is required to control erosion resulting from concentrated runoff and where such control can be achieved by this practice alone or in combination with others.

#### **4. Design Criteria.**

#### **5. Capacity.**

The minimum capacity shall be that required to confine the peak rate of runoff expected from a ten (10) year frequency rainfall event or a higher frequency corresponding to the hazard involved. This requirement for confinement may be waived on slopes of less than one (1) percent where out-of-bank flow will not cause erosion or property damage.

Where there is base flow, it shall be handled by a subsurface drain or a stone or gabion mattress lined low flow channel. The capacity of the subsurface drain or low flow channel shall be five (5) percent of the design peak flow or as determined by actual measurement of the maximum base flow.

The design procedure for parabolic and trapezoidal channels is contained in the Drainage Criteria Manual.

#### **6. Velocity and Grade.**

The maximum permissible velocities of flow for the native grasses and soil conditions in Travis County have not been determined. Research of this type is planned, but until it is completed, design velocities should be held to below six (6) feet per second on grades up to five (5) percent, five (5) feet per second on slopes from five (5) to ten (10) percent and four (4) feet per second on slopes over ten (10) percent.

## **7. Cross Section.**

The design water surface elevation of a waterway receiving water from diversions or other tributary channels shall be equal to or less than the design water surface elevation in the diversion or other tributary channels (see Figures 1-19 and 1-20 in Appendix V of this manual for "Grass-Lined Swales" for details).

## **8. Outlets.**

Each waterway shall have a stable outlet. The outlet may be another waterway, a stabilized open channel, grade stabilization structure, etc. In all cases, the outlet must discharge in such a manner as not to cause erosion. Outlets shall be constructed and stabilized prior to the operation of the waterway.

## **9. Drainage.**

Subsurface drainage measures shall be provided for sites having high water tables or seepage problems, except where water-tolerant vegetation, such as Switch grass or Indian grass can be used.

Where there is base flow, a subsurface drain or concrete low flow channel shall be required.

## **10. Stabilization.**

Waterways shall be stabilized immediately after final grading in accordance with the appropriate standards for critical area stabilization.

### **C. Level Spreader.**

(See 1.6.7.B.1 for Rock Level Spreader specifications *and refer to* 1.6.7.B Vegetative Filter Strips *for design criteria.*)

#### **1. Description.**

An outlet constructed at zero (0) percent grade across the slope whereby concentrated runoff may be discharged at nonerosive velocities into undisturbed area stabilized by existing vegetation.

#### **2. Purpose.**

The purpose of the level spreader is to convert a concentrated flow of sediment-free runoff (e.g., diversion outlets) into sheet flow and to outlet it onto areas stabilized by existing vegetation without causing erosion.

#### **3. Conditions Where Practice Applies.**

The level spreader is used only in those situations where the spreader can be constructed on undisturbed soil, where the area directly below the level lip is stabilized by existing vegetation, where the drainage area above the spreader is stabilized by existing vegetation and where the water will not be reconcentrated immediately below the point of discharge.

#### **4. Design Criteria.**

The design criteria for level spreader shall be a maximum of one (1) cubic foot per second per foot of length, based on the peak rate of flow from a ten (10) year frequency rainfall event. The minimum length shall be five (5)

feet. An alternate such as grade stabilization structure, grassed waterway, etc., should be considered where the length of the level spreader exceeds 20 feet.

## **5. Outlets.**

Final discharge will be over the level lip protected with fiber glass matting erosion stops and jute or excelsior protective material onto an existing stabilized area. The stabilized area shall have a complete vegetative cover sufficiently established to be erosion resistant.

### **D. Stone Riprap.**

#### **1. Description.**

A layer of loose rock or aggregate placed over an erodible soil surface.

#### **2. Purpose.**

The purpose of riprap is to protect the soil surface from the erosive forces of water.

#### **3. Condition Where Practice Applies.**

This practice applies to soil-water interfaces where the soil conditions, water turbulence and velocity, expected vegetative cover and ground water conditions are such that the soil may erode under the design flow conditions. Riprap may be used, as appropriate, at such places as storm drain outlets, channel banks and/or bottoms, roadside ditches, drop structures and shorelines.

#### **4. Design Criteria.**

The minimum design discharge for the portion of channels and ditches protected with stone riprap shall be the peak discharge from a ten (10) year frequency rainfall event. The roughness coefficient, "n", to be used for determining flow on the constructed riprap surface shall be:

$$n = 0.022$$

#### **5. Riprap Size Gradation.**

The curve in [Figure 1-22](#) in Appendix V of this manual gives the individual minimum stone size (diameter and weight of a spherical specimen) for a range of channel velocities up to 17 feet per second.

A well-graded mixture, as used herein, is defined as a mixture composed primarily of the larger stone sizes, but with a sufficient mixture of other sizes to fill the progressively smaller voids between the stones. A riprap layer containing 40 percent of the rock pieces smaller than the required size is more stable than a single stone of the required size. Most of the mixture should consist of stones having length, width and thickness dimensions as nearly equal as practical and of curve weight as shown in [Figure 1-22](#) in Appendix V of this manual, or more (weight is computed on the basis of 150 pounds per cubic foot) and should not be flat slabs.

The riprap layer should be a minimum of 1.5 times as thick as the dimension of the larger stones (curve size).

**6. Filter.**

A filter is a layer of material placed between the riprap and the underlying soil surface to prevent soil movement into and through the riprap.

Riprap should, in most cases, have a filter placed under it. A filter can be of two (2) general forms. One is a single layer of plastic filter cloth manufactured for that express purpose. Another is a properly graded layer of sand, gravel or stone.

Riprap that is 12 inches or larger shall not be dumped directly onto the plastic filter cloth, since it may tear or displace the filter cloth. Instead, a four (4) inch minimum thickness of blanket of gravel shall be placed over the filter cloth or riprap shall be placed directly on the filter cloth by hand or by the equipment bucket. Side slopes shall be 2:1 or flatter in order for the gravel not to slide down the filter cloth before placing the riprap.

**E. Gabions.**

(See Standard Specifications manual item 594S and Specifications manual item 594S-1 and 594S-2 for detail)

**1. Description.**

Compartmented rectangular containers made of heavily galvanized and plastic-coated steel wire woven in a uniform hexagonal pattern, with an opening of approximately three (3) x four (4) inches, then filled with stone.

**2. Purpose.**

The purpose of gabions is to protect the soil surface from the erosive forces of water or to retain unstable soil in a more vertical condition.

**3. Condition Where Practice Applies.**

This practice applies to soil faces where the soil conditions, erosive forces, expected vegetative cover and ground water conditions are such that the soil may erode under the design conditions. Gabions may be used, as appropriate, at such places as storm drain outlets, weirs, channel banks and/or bottoms, roadside ditches, drop structures, shorelines and earth retaining structures.

**4. Design Criteria.**

The minimum design discharge for that portion of channels and ditches protected with gabions shall be peak discharge from a ten (10) year frequency rainfall event. The roughness coefficient, "n", to be used for determining flow in the gabion protected channel shall be:

**Table 1.4-G Roughness Coefficient for Gabions**

n	Stone Size
0.028	4 inches

<b>n</b>	<b>Stone Size</b>
0.029	5 inches
0.030	6 inches
0.031	7 inches
0.0315	8 inches

Source: City of Austin, TX

Gabion weirs should be founded on a gabion apron which extends downstream. The length of the apron will vary with the hydraulic and soil conditions.

In no case will the apron extend downstream less than the minimum length shown in Table 1.4-H below:

**Table 1.4-H Apron Length**

<b>Gravel</b>	<b>6 feet</b>
Coarse or Medium Sand	9 feet
Fine or Silty Sand	12 feet
Clay	9 feet

Source: City of Austin, TX

Gabion earth retaining structures will be designed in conformance with the manufacturer's recommendations.

### **5. Materials.**

The wire mesh shall consist of plastic-coated (polyvinyl chloride) galvanized wire with a diameter of 0.0842 inches forrevet mattress and 0.155 inch for all other applications. The wire for salvages and corners shall be plastic-coated galvanized wire with a diameter of 0.1305 inch. Tie and connecting wire shall be plastic-coated wire with a diameter of 0.084.

The stone fill material shall consist of hard, durable, clean stone, four (4) to eight (8) inches in size.

## **F. Subsurface Drain.**

### **1. Description.**

A conduit, such as pipe or tubing, installed beneath the ground surface which intercepts, collects and/or conveys drainage water.

### **2. Purpose.**

A subsurface drain may serve one (1) or more of the following purposes:

- Improve the soil environment for vegetable growth by regulating the water table and ground water flow.
- Intercept and prevent ground water movement into a wet area and to handle base flow for grassed waterways.
- Relieve artesian pressures.
- Remove surface runoff.
- Provide internal drainage of slopes to improve their stability and reduce erosion.
- Provide internal drainage behind bulkheads, retaining walls, etc.
- Replace existing subsurface drains that are interrupted or destroyed by construction operations.
- Provide subsurface drainage to dewater stormwater management structures.
- Improve dewatering of sediment in sediment basins (see Section [1.4.5](#) K "Sediment Basins" for additional information).

### **3. Conditions Where Practice Applies.**

Subsurface drains are used where lowering or controlling ground water or surface runoff is required. The soil shall have enough depth and permeability to permit installation of an effective system. This standard does not apply to storm drainage systems or foundation drains.

An outlet for the drainage systems shall be available, either by gravity flow or by pumping. The outlet shall be adequate for the quantity of water to be discharged without damage above or below the point of discharge.

### **4. Design Criteria.**

The required capacity shall be determined by one (1) or more of the following:

- Where subsurface drainage is to be uniform over an area through a systematic pattern of drains, a drainage coefficient of one (1) inch to be removed in 24 hours shall be used.
- Where subsurface drainage is to be by random system, a minimum inflow rate of 1.5 cubic feet per second per 1,000 feet of line shall be used to determine the required capacity.

For interceptor subsurface drains on sloping land, increase the inflow rate as follows:

<b>Land Slopes</b>	<b>Increase Inflow Rate By</b>
--------------------	--------------------------------

2 - 5 percent	10 percent
---------------	------------

5 - 12 percent	20 percent
----------------	------------

over 12 percent	30 percent
-----------------	------------

- Additional design capacity must be provided if surface water is allowed to enter the system.

#### **5. Size of Subsurface Drain.**

The size of the subsurface drains shall be determined in accordance with the Drainage Criteria Manual.

#### **6. Depth and Spacing.**

The minimum depth of cover of subsurface drains shall be 24 inches, where possible. The minimum depth of cover may be reduced to a minimum of 12 inches where it is not possible to attain the 24 inch depth and where the drain is not subject to damage by equipment loading. Roots from some types of vegetation can plug drains as the drains get closer to the surface.

The spacing of drain laterals will be dependent on the permeability of the soil, the depth of installation of the drains and degree of drainage required. Generally, drains installed 36 inches deep and spaced 50 feet center to center will be adequate.

#### **7. Minimum Velocity and Grade.**

The minimum grade for subsurface drains shall be 0.10 percent. Where surface water enters the system, a velocity of not less than two (2) feet per second shall be used to establish the minimum grades. Provisions shall be made for preventing debris or sediment from entering the system by means of filters or collection and periodic removal of sediment from installed traps.

#### **8. Materials for Subsurface Drains.**

Acceptable subsurface drain materials include perforated, continuous closed joint conduits of polyethylene plastic, concrete, corrugated metal, asbestos-cement, bituminized fiber and polyvinyl chloride.

The conduit shall meet strength and durability requirements of the site.

#### **9. Loading.**

The allowable loads on subsurface drain conduits shall be based on the trench and bedding conditions specified for the job. A safety factor of not less than 1.5 shall be used in computing the maximum allowable depth of cover for a particular type of conduit.

#### **10. Envelopes and Envelope Material.**

Envelopes shall be used around subsurface drains for proper bedding of the conduit. Not less than ten (10) inches of envelope material shall be used for sand-gravel envelopes. Where necessary to improve the characteristics of flow of ground water into the conduit, more envelope material may be required.

Envelope material shall be placed to the height of the uppermost seepage strata. Behind bulkhead and retaining walls, it shall go to within 12 inches of the top of the structure. This does not cover the design of filter materials where needed.

Materials used for envelopes shall not contain materials which will cause an accumulation of sediment in the conduit or render the envelope unsuitable for building of the conduit. Envelope materials shall consist of sand-gravel material, all of which shall pass a 1-½ inch sieve, 90 to 100 percent shall pass a ¾ inch sieve and not more than ten (10) percent shall pass a Number 40 sieve.

The conduit shall be placed and bedded in a sand-gravel envelope. A minimum of three (3) inches depth of envelope material shall be placed on the bottom of a conventional trench. The conduit shall be placed on this and the trench completely filled with envelope material to a minimum depth of three (3) inches above the conduit.

#### **Envelope Material.**

Soft or yielding soil under the drain shall be stabilized where required and lines protected from settlement by adding gravel or other suitable material to the trench, by placing the conduit on plank or other rigid support or by using long sections of perforated or watertight pipe with adequate strength to insure satisfactory subsurface drain performance.

The envelope shall be interrupted every ten (10) feet by an impervious cutoff wall. This wall shall fit tightly around the pipe and prohibit the continued flow of water through the envelope, thus forcing it into the conduit.

#### **11. Auxiliary Structure and Subsurface Drain Protection.**

The outlet shall be protected against erosion and undermining of the conduit, against damaging periods of submergence and against entry of rodents or other animals into the subsurface drain.

A continuous ten (10) foot section of corrugated metal, cast iron, polyvinyl chloride or steel pipe without perforations shall be used at the outlet end of the line and shall outlet above the normal elevation of low flow in the outlet ditch. No envelope material shall be used around the ten (10) foot section of pipe. Two-thirds (2/3) of the pipe shall extend to a point above the toe of the ditch side slope or the side slope shall be protected from erosion.

Conduits under roadways and embankments shall be watertight and designed to withstand the expected loads.

Where surface water is to be admitted to subsurface drains, inlets shall be designed to exclude debris and prevent sediment from entering the conduit. Lines flowing under pressure shall be designed to withstand the resulting pressures and velocity of flow. Surface waterways shall be used where feasible.

The upper end of each subsurface drain line shall be capped with a tight fitting cap of the same material as the conduit or other durable material, unless connected to a structure.

## **G. Land Grading.**

### **1. Description.**

Reshaping of the existing topography in accordance with a plan as determined by engineering survey and layout.

### **2. Purpose.**

The purpose of land grading is to provide for erosion control and vegetative establishment on those areas where the existing topography is to be reshaped by grading according to plan.

### **3. Design Criteria.**

The grading plan should be based upon the incorporation of building designs and street layouts that fit and utilize existing topography and desirable natural surroundings to avoid extreme grade modifications. Information submitted will provide sufficient topographic surveys and soil investigations to determine limitations that must be imposed on the grading operation related to slope stability, effect on adjacent properties and drainage patterns, measures for drainage and water removal and vegetative treatment, etc.

The plan must show existing and proposed contours of the area(s) to be graded. The plan shall also include practices for erosion control, slope stabilization, safe disposal of runoff water and drainage, such as waterways, lined ditches, reverse slope benches (include grade and cross section), grade stabilization structures, retaining walls and surface and subsurface drains. The plan shall also include scheduling and phasing of these practices; the following shall be incorporated into the plan:

- Provisions shall be made to safely conduct surface runoff to storm drains, protected outlets or to stable water courses to insure that surface runoff will not damage slopes or other graded areas (see Section [1.4.6](#)"Permanent Structural Practices").
- Cut and fill slopes shall be designed to the natural angle of repose for the material. Without approval of the Director of Transportation and Public Services, they will be no steeper than 2:1, except for cut slopes in solid limestone. Where the slope is to be mowed, the maximum slope shall be no steeper than 3:1 (4:1 is preferred because of safety factors related to mowing steep slopes).
- Reverse slope benches or diversions shall be provided whenever the vertical interval (height) of any 2:1 through 5:1 slope exceeds 15 feet. Benches shall be located so as to divide the slope face as equally as possible and shall convey the water to a stable outlet. Soils, seeps, rock outcrops, etc., shall also be taken into consideration when designing benches.
  - Benches shall be wide enough to accommodate the construction equipment in use and provide for ease of maintenance.
  - Benches shall be designed with a reverse slope of 5:1 or flatter to the toe of the upper slope and with a minimum of one (1) foot in

depth. Bench gradient to the outlet shall be between one (1) and two (2) percent.

- The flow length within a bench shall not exceed 800 feet unless accompanied by appropriate design and computations (see Section [1.4.25](#) "Temporary Structural Practices").
- Surface water shall be diverted from the face of all cut and/or fill slopes by the use of diversions, ditches and swales or conveyed down slope by the use of designed structure, except where:
  - The length of overland flow (in feet) to the crest of the slope shall not exceed the distance "A" given in the following diagram and example for any combination of side slopes and vertical intervals and;
  - The face of slope is or shall be stabilized and the face of all graded slopes shall be protected from surface runoff until they are stabilized and;
  - The face of the slope shall not be subjected to any concentrated flows of surface water from natural drainageways, graded swales, downspouts, etc.

The maximum total horizontal overland flow distance "B" shall not exceed 15 times the side slope "X" of the cut or fill slope. Maximum allowable overland flow distance (in feet) to the top of the slope with no diversion of surface water will be determined by use of the formulas found in Section 2 "Determination of Storm Runoff" of the Drainage Criteria Manual.

#### **H. *Grade Stabilization Structure (Paved Chute or Flume).***

##### **1. Definition.**

A channel lined with bituminous concrete, Portland cement concrete or comparable non-erodible material placed to extend from the top of a slope to the bottom of a slope.

##### **2. Purpose.**

The purpose of the paved chute or flume is to convey surface runoff safely down slopes without causing erosion.

##### **3. Conditions Where Practice Applies.**

A paved chute or flume is to be used where concentrated flow of surface runoff must be conveyed down a slope in order to prevent erosion. The maximum allowable drainage area shall be 36 acres.

##### **4. Design Criteria.**

- Size Group A.
  - The height (H) of the dike at the entrance is at least 1.5 feet.
  - The depth (d) of the chute down the slope is at least eight (8) inches.
  - The length (L) of the inlet and outlet sections is five (5) feet.

- Size Group B.
  - The height (H) of the dike at the entrance is at least two (2) feet.
  - The depth (d) of the chute down the slope is at least ten (10) inches.
  - The length (L) of the inlet and the outlet sections is six (6) feet.

Each size group has various bottom widths and allowable drainage areas as shown below:

**Table 1.4-I Grade Stabilization Structure Size Data**

Size 1/	Bottom Width, b, Ft.	Maximum Drainage Area Acres
A-2	2	5
A-4	4	8
A-6	6	11
A-8	8	14
A-10	10	18
B-4	4	14
B-6	6	20
B-8	8	25
B-10	10	31
B-12	12	36

**Note:** 1/ The size is designated with a letter and a number, such as A-6, which means a chute or flume in Size Group A with a six (6) foot bottom width. The selected size shall be shown on the plans.

If a minimum of 75 percent of the drainage area will have a good grass or woodland cover throughout the life of the structure, the drainage areas listed above may be increased by 50 percent. If a minimum of 75 percent of

the drainage area will have a good mulch cover throughout the life of the structure, the drainage areas listed above may be increased by 25 percent.

#### **5. Outlet.**

When a paved chute or flume is used, the velocity at its outfall shall be checked for erosion potential downstream and when required, energy dissipation structures shall be installed.

### **1.4.7 Vegetative Practices**

#### **A. Temporary Vegetative Stabilization of Disturbed Areas**

##### **1. Description.**

Stabilize soil in disturbed areas with temporary vegetation. Refer to ECM Section 1.4.5.A. – Mulching for other temporary stabilization options.

##### **2. Purpose.**

To stabilize the soil; reduce damages from sediment and runoff to downstream areas; improve wildlife habitat; and enhance natural beauty.

##### **3. Conditions Where Practice Applies.**

Use vegetation to temporarily stabilize the soil on disturbed, graded or cleared areas prior to establishment of permanent vegetation.

##### **4. Design Criteria.**

Prior to vegetative establishment, install needed erosion control practices, such as diversions, grade stabilization structures, berms, dikes, level spreaders, and sediment basins. Final grading and shaping has usually not been completed for temporary stabilization.

##### **5. Fertilizer**

For temporary vegetative establishment, apply slow-release fertilizer with an analysis of 15-15-15 at the rate of .5 pounds of nitrogen per 1,000 square feet once at planting and once during the period of establishment. Approval from the Watershed Protection and Development Review Department must be obtained if a higher rate of fertilizer is proposed. The timing of the fertilization shall correspond with the installation of vegetation. In order to avoid the conveyance of nutrients off-site, the timing shall not occur when rainfall is expected.

##### **6. Seed Bed Preparation.**

Prepare a suitable seed bed which allows good seed-to-soil contact and soil conditions that are conducive to vegetative growth. Do not disturb the soil within the critical root zone of existing trees. See Section 1.4.8.B. for information regarding the protection of trees in construction areas.

Areas of compacted soil shall be loosened to a depth of at least two (2) inches by plowing, discing, raking or other acceptable means before seeding.

In areas where no topsoil exists, or where fill is needed, the subgrade shall be loosened by discing or by scarifying to a depth of at least two (2) inches to permit bonding of the topsoil to the subsoil.

Topsoil, when used, shall meet the definition of topsoil as defined in standard specification 601S.3.A Salvaging and Placing Topsoil.

Topsoil salvaged from the existing site may often be used, but it should meet the same standards as set forth in these standards.

**7. Seeding.**

If seeding is to be conducted during the cool season (November 1 to February 15). Select species noted as “cool season cover crop” from the Tables in Standard Specification 604S and/or 609S. If seeding is to be conducted during the warm season (February 16 to October 31) use one of the following options (whichever is applicable):

- Native Seeding: Green Sprangletop (*Leptochloa dubia*) at the rate of 4 lbs. per acre.
- Non-native Seeding: Comply with one of the options described in 604S.5 using Bermuda grass.

Apply seed uniformly with a cyclone seeder spreader, drill, cultipacker seeder or hydroseeder (slurry includes seed, fertilizer and binder – see item 8. [next]).

**8. Protection of Seed Bed with Hydromulching-or Soil Retention Blanket.**

Newly-installed temporary vegetation must be protected by hydromulch or soil retention blanket (refer to Standard Specification 605S Soil Retention Blanket).immediately after seeding. Protection of the seed bed shall occur in a manner that will allow seed germination and that encourages effective vegetative growth. Hydromulching, when used, shall comply with the requirements shown in the table below: Hydromulching for Temporary Vegetative Stabilization.

**Table 1.4-J Hydromulching for Temporary Vegetative Stabilization**

Material	Description	Longevity	Typical Applications	Application Rates
70/30 Wood/ Cellulose Blend Mulch	70% Wood 30% Paper 3% Tackifier	0-3 months	Moderate slopes; from flat to 3:1	45.9 lbs/1000 sf
Wood Fiber Mulch	96% Wood 3% Tackifier	0-3 months	Moderate slopes; from flat to 3:1	45.9 lbs/1000 sf

**70/30 Wood/Cellulose Blend Fiber Mulch.** Wood/Cellulose blend fiber mulch shall consist of 70% long wood grain fibers produced from grinding clean, whole wood chips and 30% cellulose fiber produced from ground newsprint. Refer to Table 1.4-K for mulch properties and to Standard Specification 604S – Seeding for additional mulch requirements.

**Table 1.4-K Properties of 70/30 Wood/Cellulose Blend Fiber Mulch**

Property (Test Method)	Required Value
Moisture content %	12.0% ±3.0% (max.)
Organic matter % - wood fiber	70% ±1% Oven Dry Basis (min.)
Organic matter % - paper fiber	30.0% ±1% Oven Dry Basis (max.)
Tacking Agent	3.0% (min.)
Water holding capacity	1,000 Grams of water per 100 grams of fiber (min.)

**Wood Fiber Mulch.** Wood fiber mulch shall consist of 100% long wood grain fibers produced from grinding clean, whole wood chips. . Refer to Table Table 1.4-L for mulch properties and to Standard Specification 604S – Seeding for additional mulch requirements.

**Table 1.4-L Properties of Wood Fiber Mulch**

Property (Test Method)	Required Value
Moisture content %	12.0% ±3.0% (max.)
Organic matter % - wood fiber	96% ±1% Oven Dry Basis (min.)
Organic matter % - paper fiber	30.0% ±1% Oven Dry Basis (max.)
Tacking Agent	3.0% (min.)
Water holding capacity	1,000 Grams of water per 100 grams of fiber (min.)

## **9. Watering**

Seed germination will be expected within 1 week of sowing. Watering is required to germinate seed and maintain growth. Seedlings shall be watered daily, or more often as necessary to ensure growth and to ensure that the vegetative cover stabilizes the soil as required.

### ***B. Permanent Vegetative Stabilization of Disturbed Areas***

#### **1. Description.**

Planting vegetation such as grasses, forbs, and/or sod on disturbed areas. Permanent vegetative stabilization for disturbed areas may be achieved either by means of seeding or by sodding. When seeded, newly-installed permanent vegetation must be protected by hydromulch or soil retention blanket (refer to Standard Specification 605S Soil Retention Blanket).

#### **2. Purpose.**

To stabilize the soil, to reduce damages from sediment and runoff to downstream areas, improve wildlife habitat, enhance natural beauty.

#### **3. Conditions Where Practice Applies.**

Disturbed, graded or cleared areas which are subject to erosion and where a permanent, long-lived vegetative cover is needed.

#### **4. Design Criteria.**

##### **Standard Specifications.**

For areas that are seeded refer to Standard Specification 604S – Seeding for Erosion Control or 609S – Native Grassland Seeding and Planting for Erosion Control (whichever is applicable). For areas that are sodded refer to Standard Specification 602S – Sodding for Erosion Control.

##### **Site Preparation.**

- Install needed erosion control practices, such as interceptor dikes, berms and spreaders, contour ripping, erosion stops, channel liners and sediment basins.
- Grade as needed and feasible to permit the use of conventional equipment for seed bed preparation, seeding, mulch applications, anchoring and maintenance.

#### **5. Bed Preparation.**

Prepare a suitable bed which allows good contact between the soil and the seed or sod (whichever is used).

Areas of compacted soil shall be loosened by plowing, discing, raking or other acceptable means to a depth of six (6) inches or greater prior to seeding.

In areas where no topsoil exists, or where fill is needed, the subgrade shall be loosened by discing or by scarifying to a depth of at least two (2) inches to permit bonding of the topsoil to the subsoil.

Topsoil, when used, shall meet the definition of topsoil as defined in standard specification 601S.3.A Salvaging and Placing Topsoil.

Topsoil salvaged from the existing site may often be used, but it should meet the same standards as set forth in these standards.

**6. Fertilizer**

For permanent vegetative establishment, apply fertilizer shall be applied with an analysis of 15-15-15 at the rate of .5 pounds of nitrogen per 1,000 square feet. Approval from the Watershed Protection and Development Review Department must be obtained if a different type or rate of fertilizer is proposed. The timing of the fertilization shall correspond with the installation of vegetation. In order to avoid the conveyance of nutrients off-site, the timing shall not occur when rainfall is imminent.

**7. Seeding.**

Select the appropriate species in the tables provided in Standard Specification 604S and/or 609S. All seeding work must conform to these specifications.

**8. Protection of Seed Bed with Hydromulch or Soil Retention Blanket.**

When seeded, newly-installed permanent vegetation must be protected by hydromulch or soil retention blanket (refer to Standard Specification 605S Soil Retention Blanket) immediately after seeding. Protection of the seed bed shall occur in a manner that will allow seed germination and that encourages effective vegetative growth. Hydromulching, when used, shall comply with the requirements of shown in the table Hydromulching for Permanent Vegetative Stabilization.

**Table 1.4-M Hydromulching for Permanent Vegetative Stabilization**

<b>Material</b>	<b>Description</b>	<b>Longevity</b>	<b>Typical Applications</b>	<b>Application Rates</b>
Bonded Fiber Matrix (BFM)	80% Wood or Organic Fibers 10% Tackifier	6 months	On slopes up to 2:1 and erosive soil conditions	68.9 lbs/SF to 80.3 lbs/ 1000SF
Fiber Reinforced Matrix (FRM)	75% Wood or Organic Fibers 5% Reinforcing Fibers 10% Tackifier	12 months	On slopes up to 1:1 and erosive soil conditions	68.9 lbs/SF to 80.3 lbs/ 1000SF

**Bonded Fiber Matrix (BFM):** Bonded Fiber Matrix shall consist of long thermally refined wood fibers produced from grinding clean, whole wood chips and cross-linked hydro-colloidal tackifiers. Refer to Table 1.4-N for

mulch properties and to Standard Specification 604S – Seeding for additional mulch requirements.

**Table 1.4-N Properties of Bonded Fiber Matrix**

<b>Property (Test Method)</b>	<b>Required Value</b>
Moisture content %	10.0% ±3.0% (max.)
Organic matter % - wood fiber	80% ±3% Oven Dry Basis (min.)
Cross-linked Hydro-colloidal Tackifiers	10.0% ±1%
Water holding capacity	500% or greater
Mass per unit area (ASTM D6566)	10.0 oz/square yard (min.)
Thickness (ASTM D6525)	0.12 inch (min.)
Ground Cover (ASTM D6567)	97 % (min.)
Functional Longevity	6 months (min.)
% Effectiveness	90% (min.)
Cure time	None
Cure time	None
Vegetative Establishment (ASTM D7322)	400%

**Fiber Reinforced Matrix (FRM).** Fiber Reinforced Matrix shall consist of long thermally refined wood fibers produced from grinding clean, whole wood chips, crimped interlocking fibers, cross-linked hydro-colloidal tackifiers and performance enhancing additives. Refer to the table below for mulch properties and to Standard Specification 604S – Seeding for additional mulch requirements.

**Table 1.4-O Properties of Fiber Reinforced Matrix**

<b>Property (Test Method)</b>	<b>Required Value</b>
Moisture content %	10.0% ±3.0% (max.)

<b>Property (Test Method)</b>	<b>Required Value</b>
Organic matter % - wood fiber	75% ±3.5% Oven Dry Basis (min.)
Organic matter % - crimped fibers	5.0% ±1.0% (min.)
Cross-linked Hydro-colloidal Tackifiers	10.0% ±1%
Water holding capacity	500% or greater
Mass per unit area (ASTM D6566)	11.0 oz/square yard (min.)
Thickness (ASTM D6525)	0.16 inch (min.)
Ground Cover (ASTM D6567)	97 % (min.)
Functional Longevity	12 months (min.)
% Effectiveness	99% (min.)
Cure time	None
Vegetative Establishment (ASTM D7322)	500%
Shear Stress (ASTM D7207)	1 psf (min.)

### **9. Sodding.**

Sodding is an acceptable practice for permanent vegetative stabilization. Installation of sod shall comply with practices described in Standard Specification 602S – Sodding. Sod placed on slopes greater than 3:1 must be staked using biodegradable landscape staples.

### **10. Irrigation.**

Provide watering as required in the Standard Specifications. Water according to the schedule described below, or to replace moisture loss per evapotranspiration (ET), whichever is greater. Significant rainfall (on-site rainfall of ½" or greater) may allow the postponement of watering until the next scheduled irrigation.

**Table 1.4-P Watering Schedule**

<b>Time Period</b>	<b>Irrigation Amount</b>	<b>Frequency</b>
At Installation	Minimum 1"	Min. 2x or 3x/day
Next 30 days	Min. 1" or replace ET	Min. 1x or 2x/day
Until Final Completion	Min. 1.5" or replace ET	As necessary

**11. Maintenance.**

Maintenance is a vital factor in providing an adequate vegetative erosion control cover.

**Reseeding** – Inspect all seeded areas for failures and reseed as necessary.

**Weeding** – Anticipate weed problems prior to planting desired plants and eradicate weeds as necessary to ensure a weed-free site. Weed types and amounts are dependent on weather, season, soil quality, and site conditions. Refer to Standard Specifications 602, 604, 608 and 609 for weed lists and treatment methods.

**Table 1.4-Q Weeding Schedule**

<b>Time Period</b>	<b>Weed Treatment</b>	<b>Frequency</b>
Prior to planting	Eradicate all weeds	2x or as necessary
At sowing/planting	Spot-treat & hand-pull	As necessary
Next 30 days	Spot-treat & hand-pull	1x/week
Until Final Completion	Eradicate all weeds	As necessary

**C. Stabilization of Disturbed Areas with Trees, Perennials, Grasses and Shrubs.**

**1. Description.**

Planting rooted vegetation, such as trees, perennials, grasses and shrubs, on disturbed areas.

**2. Purpose.**

To stabilize area, to reduce damages from sediment and runoff to downstream areas, to enhance natural beauty.

### 3. Conditions Where Practice Applies.

Graded or cleared areas subject to erosion where a permanent, long-lived diverse vegetative cover is desired.

### 4. Design Criteria.

- Preference should be given to plants that are suitable for erosion control and that establish easily on difficult sites.
- An excellent tabulation of vegetation types suited for various soil types and locations is provided in Appendix F – Descriptive Categories of Tree Species of this manual.

### 5. Planting Time.

Ideal planting times are fall and early spring. This allows for the plant to become established during periods of moderate temperatures and potentially adequate moisture.

### 6. Soil Preparation.

Soil preparation of rooted plants shall comply with practices described in Standard Specification 608S – Planting.

### 7. Irrigation.

Supply rooted plants with adequate water for growth until they plants are firmly established. Provide temporary irrigation as required in the Standard Specifications. Irrigate according to the schedule described below, or to replace moisture loss per evapotranspiration (ET), whichever is greater. Significant rainfall (on-site rainfall of ½” or greater) may allow the postponement of watering until the next scheduled irrigation.

**Table 1.4-R Irrigation Schedule**

Time Period	Irrigation Amount	Frequency
At Installation	Minimum 2”	Min. 2x or 3x/day
Next 30 days	Min. 2” or replace ET	Min. 1x or 2x/day
Until Final Completion	Min. 2.5” or replace ET	As necessary

### 8. Maintenance.

Monitoring, watering, mulching and weeding shall be required during the period of establishment to ensure planting success. Maintenance practices shall comply with construction methods and plant establishment requirements described in Standard Specification 608S – Planting.

**Weeding:** Anticipate weed problems prior to planting desired plants and eradicate weeds as necessary to ensure a weed-free site. Weed types and

amounts are dependent on weather, season, soil quality, and site conditions. Refer to Standard Specification 608 for weed lists and treatment methods.

**Table 1.4-S Weeding Schedule**

<b>Time Period</b>	<b>Weed Treatment</b>	<b>Frequency</b>
Prior to planting	Eradicate all weeds	2x or as necessary
At sowing/planting	Spot-treat & hand-pull	As necessary
Next 30 days	Spot-treat & hand-pull	1x/week
Until Final Completion	Eradicate all weeds	As necessary

### **1.4.8 Special Practices**

#### **A. *Minimizing Stripped Areas.* (See [Figure 1-29](#) in Appendix V of this manual for detail)**

##### **1. Description.**

Minimizing soil disturbance by exposing only the areas for active construction.

##### **2. Purpose.**

To expose the smallest practical area of land for the shortest possible time, thereby reducing the potential for erosion.

##### **3. Conditions Where Practice Applies.**

Where improved surfaces or vegetative cover cannot be established within 12 months of the disturbance.

Where disturbance of the natural vegetative cover may cause serious erosion and flooding problems.

Along site perimeters to help control erosion and act as a buffer zone to protect neighboring properties.

##### **4. Procedures.**

- Extent of disturbed areas shall be determined on the basis of the amount of critical areas such as steep slopes and areas of high erodibility. The proposed sequence of stripping shall be indicated on the erosion and sediment control plan.
- Watershed, subwatersheds or construction stages should be used as the basis to define specified areas.

- Stabilization operations shall be completed in a specified stripping area before disturbing the next specified area.
- Grading of particularly critical areas should be avoided during the season of maximum erosion potential (May 1-September 30).
- Equipment and vehicles shall be prohibited from maneuvering on areas designated to be undisturbed. Areas to be left undisturbed to discourage vehicular traffic should be fenced, according to City of Austin Standards.

**B. Protection of Trees in Construction Areas.**

**1. Description.**

Protection of desirable trees from mechanical and other injury while the land is being converted to urban use.

**2. Purpose.**

To employ the necessary protective measures to insure the survival of desirable trees for shade, beautification and vegetative cover.

**3. Conditions Where Practice Applies.**

On areas now occupied by single specimen trees or groups of trees.

- Criteria for deciding upon the trees to leave:
  - **Aesthetic values:** Consideration should be given to autumn foliage, flowering habits, bark and crown characteristics and type of fruit.
  - Freedom from disease and rot.
  - Life span of trees: Some are considered short-lived trees.
  - **Wildlife values:** Oaks, hickories, dogwoods, etc., have a high food value.
  - **Comfort index:** Summer temperatures are generally ten (10) degrees cooler under stands of hardwoods than cedars.
  - **Sudden exposure:** To direct sunlight and ability to withstand radiated heat from proposed buildings and pavement.
  - **Space needed:** For future growth and relationship to structures, electric and telephone lines, water and sewer lines, driveways and streets. Mark trees with bright paint or ribbon so there is no doubt as to which trees are to be left and protected from damage during construction.

**NOTE:** A more detailed discussion on the preservation of trees and the specific requirements relative to the Land Development Code is found in [Section 3.00](#) of this manual and in the City of Austin Standards and City of Austin Standard Specifications.

**C. Dust Control.**

**1. Description.**

Controlling dust movement on construction-sites and roads.

**2. Purpose.**

To prevent blowing and movement of dust from exposed soil surfaces, reduce on and off-site damage, health hazards and improve traffic safety.

**3. Conditions Where Practice Applies.**

This practice is applicable to areas subject to dust blowing and movement where on and off-site damage is likely without treatment.

**4. Procedures**

**Temporary methods:**

- **Mulches** - See Section [1.4.5.A](#)
- **Vegetative Cover** - See Section [1.4.7](#).
- **Spray-on Adhesives** - On mineral soils (not effective on muck soils). Keep traffic off these areas.

**Table 1.4-T Spray-on Adhesives**

	<b>Water Dilution</b>	<b>Type of Nozzle</b>	<b>Apply-Gal./Acre</b>
<b>Anionic asphalt emulsion</b>	7:1	Fine Spray	1,200
<b>Latex emulsion</b>	12½ :1	Fine Spray	235
<b>Resin-in-water emulsion</b>	4:1	Fine Spray	300
<b>Anionic asphalt emulsion</b>	7:1	Fine Spray	1,200

Source: City of Austin

- **Tillage** - to roughen surface and bring clods to the surface. This is an emergency measure which should be used before soil blowing starts. Begin plowing on windward side of site. Chisel-type plows spaced about 12 inches apart, spring-toothed harrows and similar plows are examples of equipment which may produce the desired effect.
- **Irrigation** - This is generally done as an emergency treatment. Site is sprinkled with water until the surface is moist. Repeat as needed.
- **Barriers** - Solid board fences, snow fences, burlap fences, crate walls, bales of hay and similar materials can be used to control air currents

and soil blowing. Barriers placed at right angles to prevailing currents at intervals of about 15 times their height are effective in controlling soil blowing.

**Permanent Methods.**

- **Permanent Vegetation** -- See Section [1.4.7](#).
- **Stone** - Cover surface with crushed stone or coarse gravel.